

## GT-LS601XXX-LX

**Product Type**  
6x6

**G-SWITCH Operating Force**

A=160gf  
B=250gf  
C=100gf

**LED Color**

N=无  
R=红色  
Y=黄色  
G=绿色  
U=蓝色  
W=白色  
O=橙色  
R/U=红发蓝  
X/O=客制化

**Switch lifetime (Force)**

L05=50,000 Cycles  
L1=100,000 Cycles

键帽颜色  
A=透明(PC)  
B=黑色(PA66)  
C=白色(POM)  
D=米黄色 (PA66)

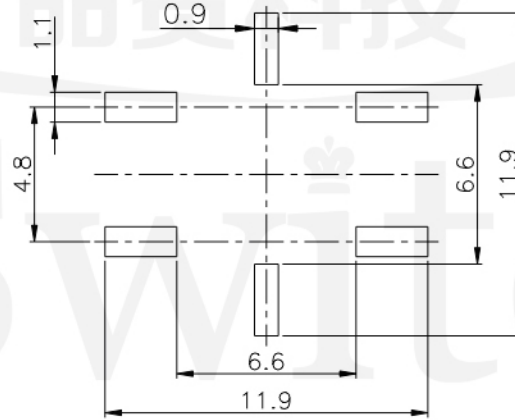
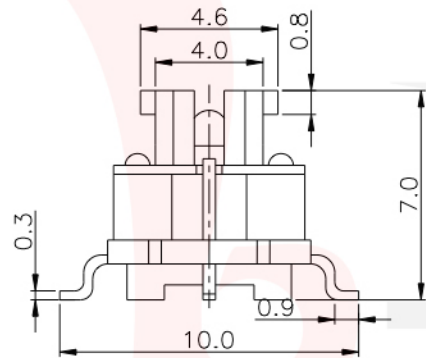

P.C.B. Layout

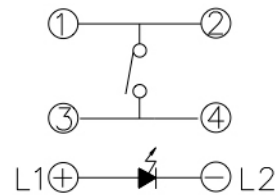
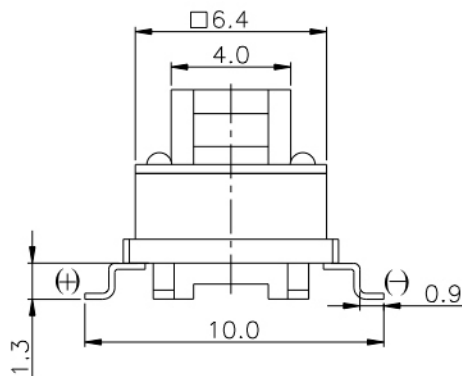

Circuit



RoHS  
Compliant  
2002/95/EC



Compliant  
Halogen Free



**G-Switch Electronic (HongKong) CO.,Ltd.**

Unless otherwise specified, Tolerance:  
X. ±0.30  
X.x ±0.20  
X.xx ±0.15  
X.xxx ±0.10  
Angles ±3°

DESIGN FengFengChen DATE 2019.05.29  
CHECKED DATE  
APPROVED DATE  
<http://www.dg-switch.com>  
TEL:0769-82388879

Molde code:  
**GT-LS601XXX-LX**  
REV.: X1 SCALE: 4:1 UNIT: mm  
SIZE: A4 SHEET: 1/1

### G-Switch Specification:

Operating temperature range : -30°Cto+85°C  
Rating : 50mA.12V DC  
Insulation resistance: : 100MΩ min.100V DC  
Dielectric strength : 250V AC for 1 min  
Contact resistance: : 100m Ω max.  
Travel:0.25±0.1mm