

*b 3.5 TOTAL TRAVEL
2.5±0.3 LOCK TRAVEL

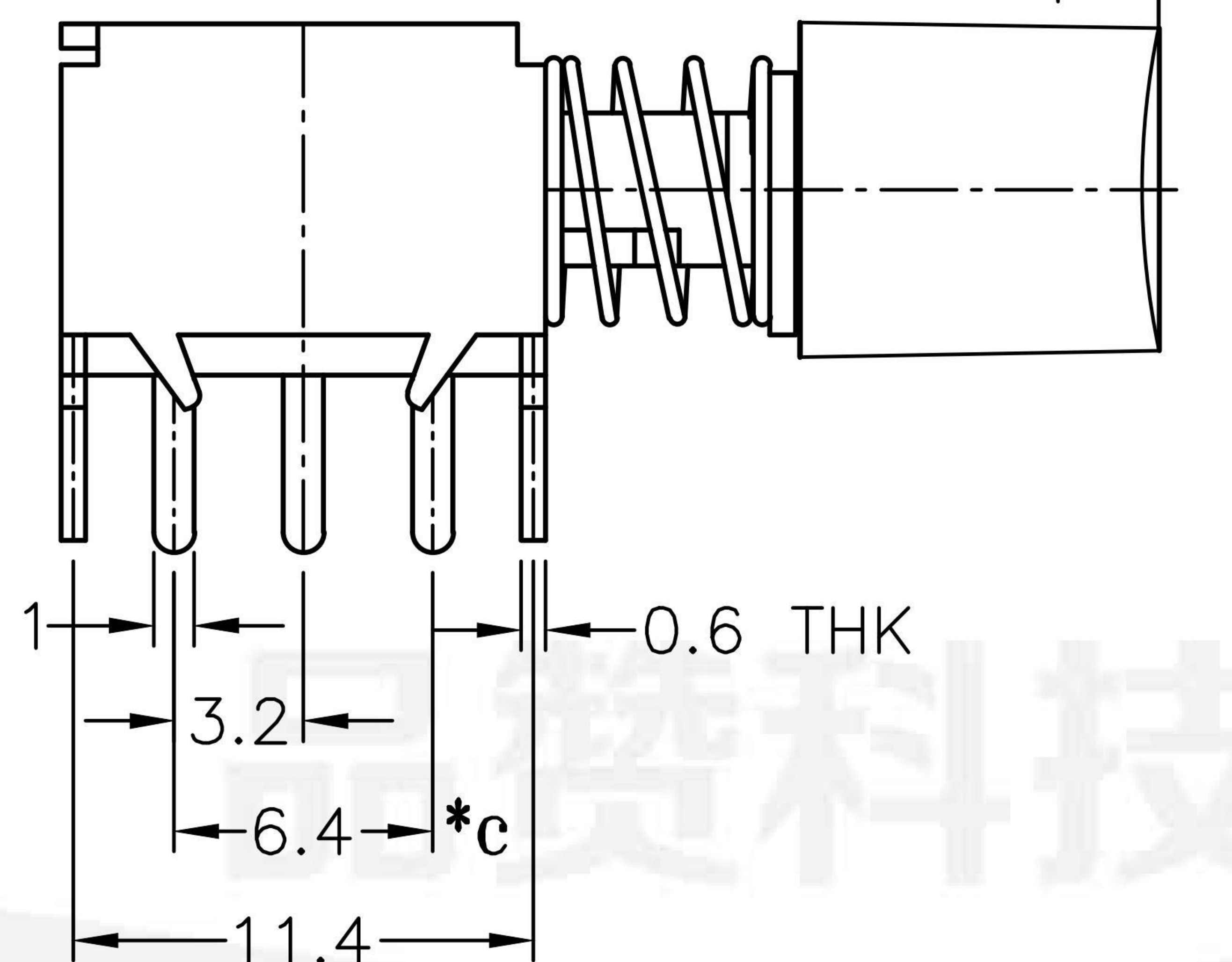

PS-22F43XX

PUSH SWITCH

G-Switch P/N

N=NO LOCK
L=LOCK

A=黑色
B=红色
C=蓝色
D=其它

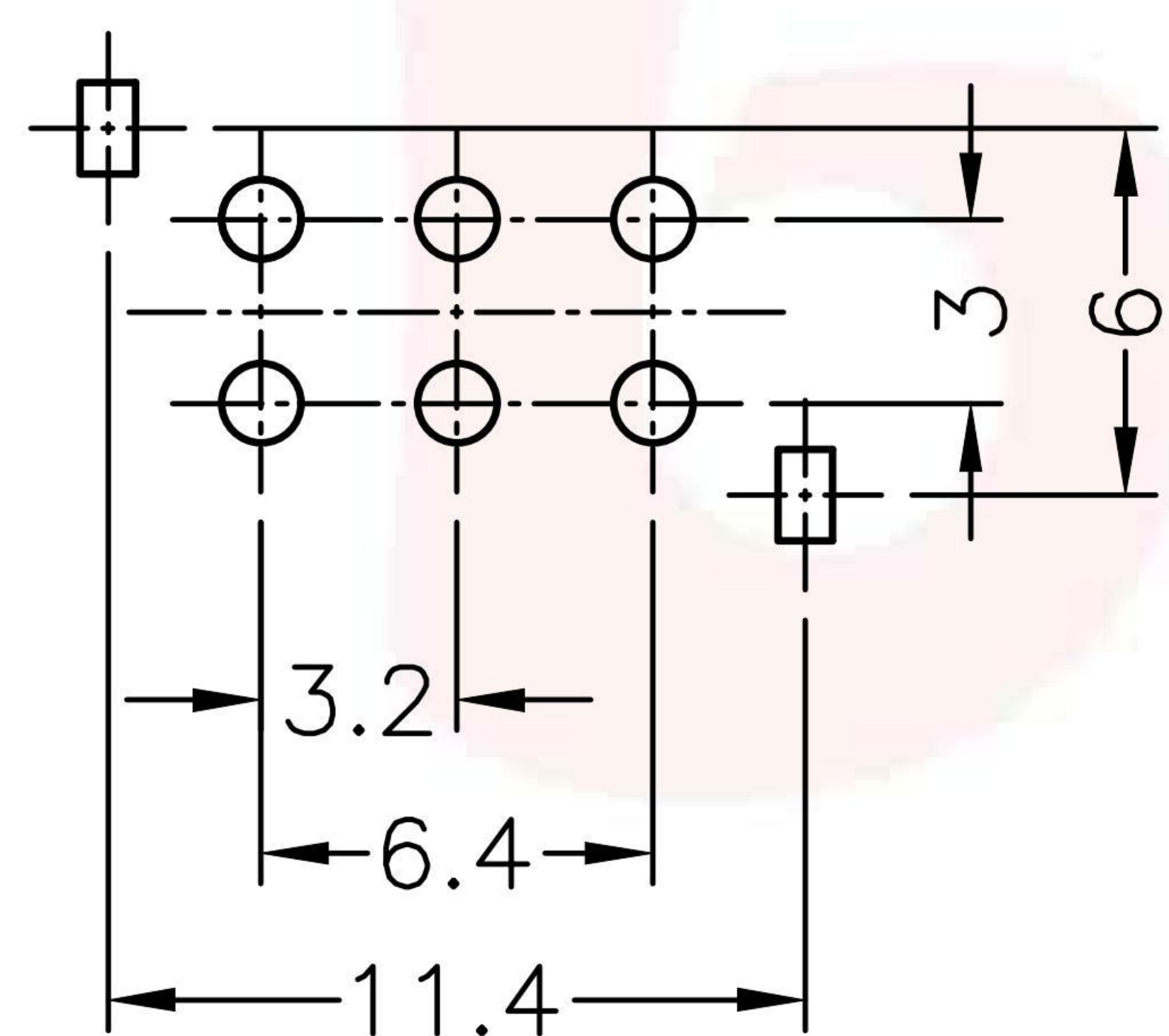

P.C.B LATOUT
BOTTOM VIEW

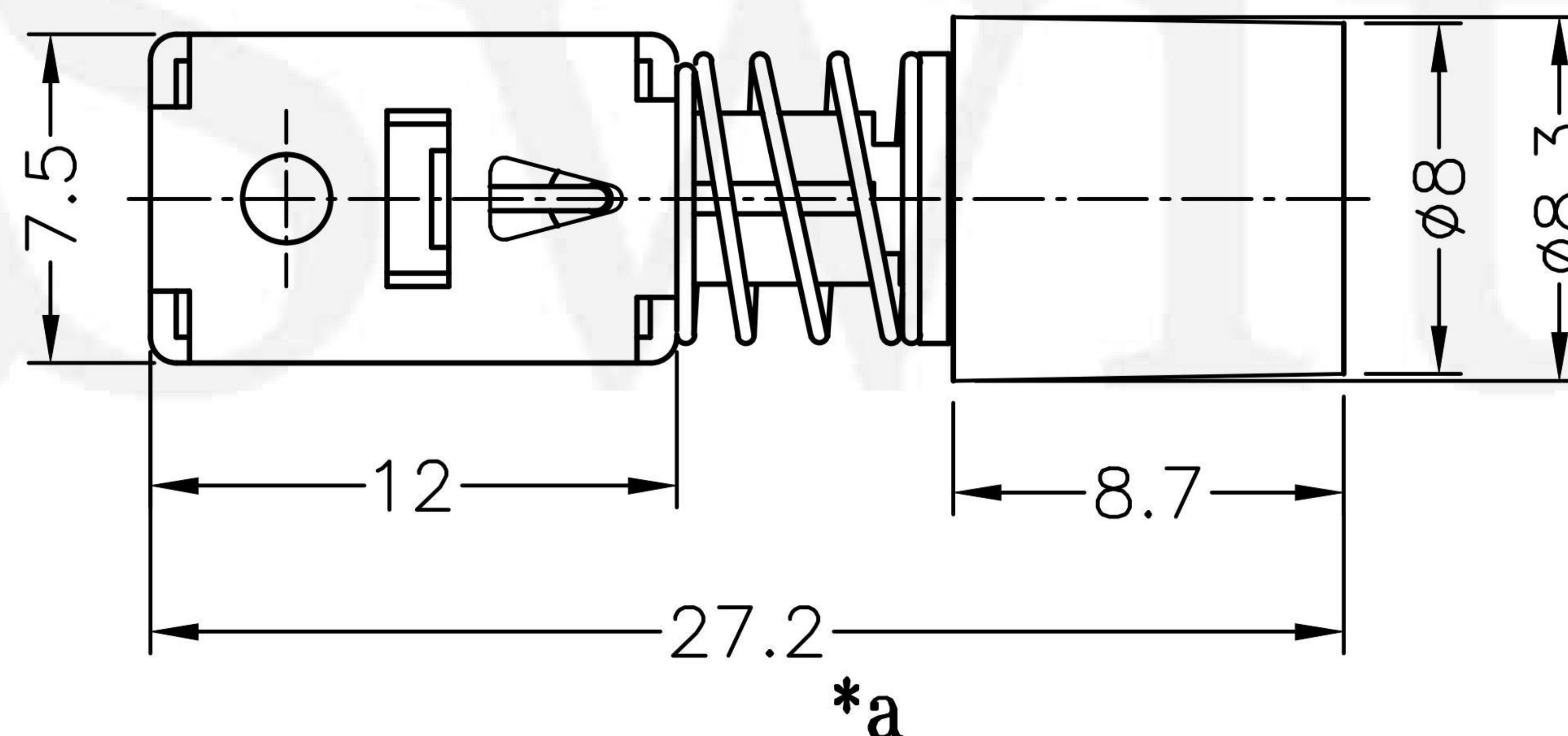

G-Switch Specification:

Electrical Specifications: 0.5A 30VDC
Contact Resistance : ≤100mΩ
Insulation Resistance: ≥100MΩ DC125V
Withstand Voltage: AC125V 1 minute
Operating Temperature: -25°C~+65°C
Storage Humidity: ≤85%RH
Electrical Life: 10,000
Mechanical Life: 100,000

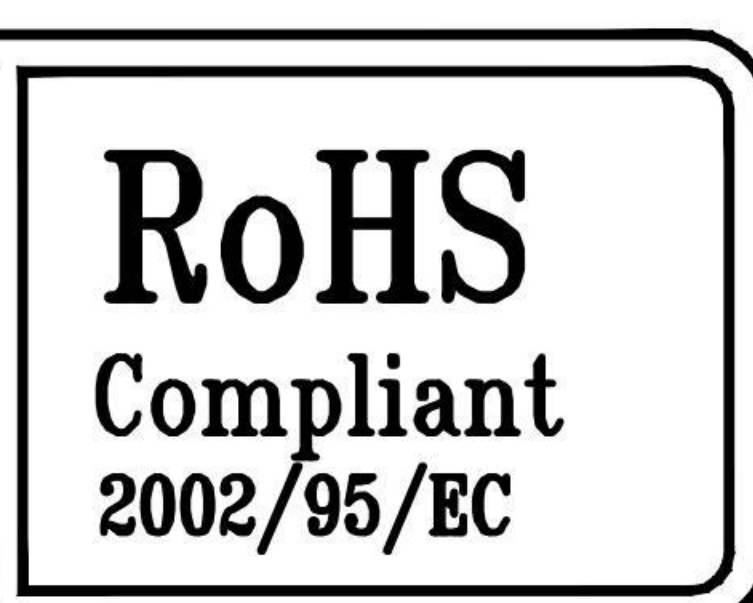
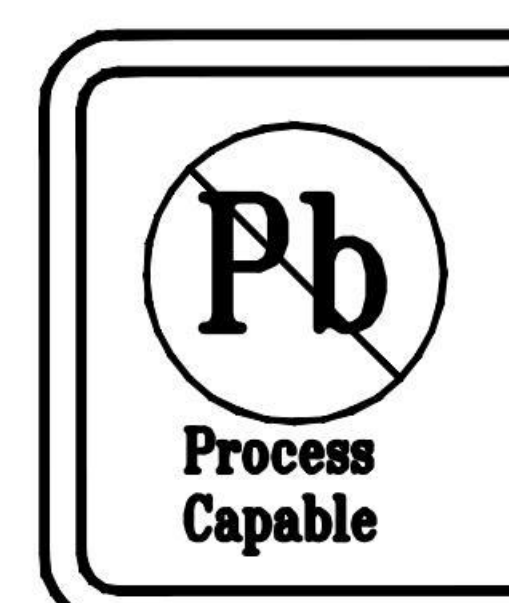
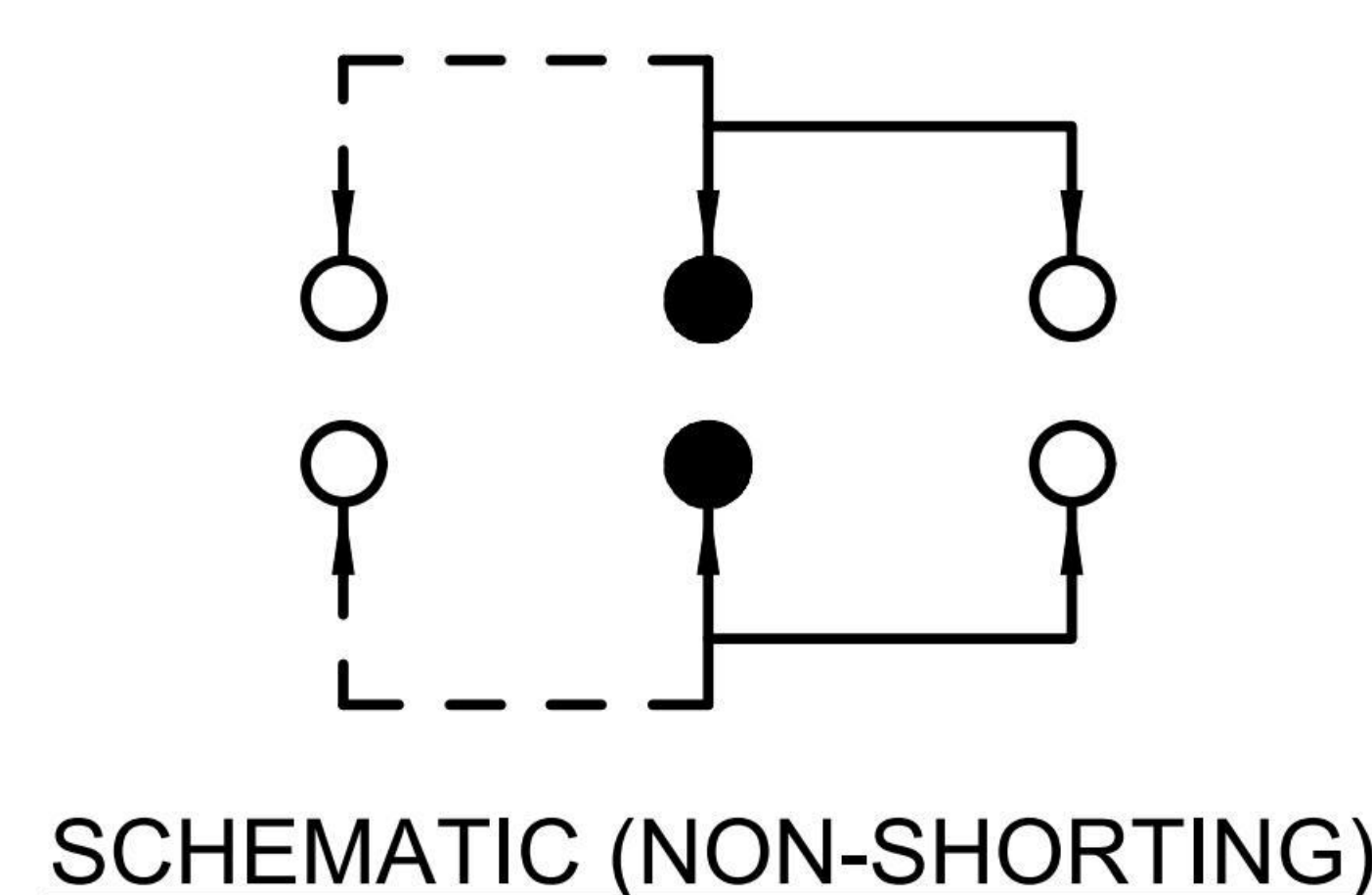

G-Switch Electronic (HongKong) CO.,Ltd.

Unless otherwise specified, Tolerance:
X. ±0.30
X.x ±0.20
X.xx ±0.15
X.xxx ±0.10
Angles ±3°

DESIGN Yvette Chen	DATE 2019.05.29
CHECKED	DATE
APPROVED	DATE
http://www.dg-switch.com	
TEL:0769-82388879	

Molde code:		
PS-22F43XX		
REV.: X1	SCALE: 4:1	UNIT: mm
SIZE: A4	SHEET: 1/1	