

CIRCUIT DIAGRAM

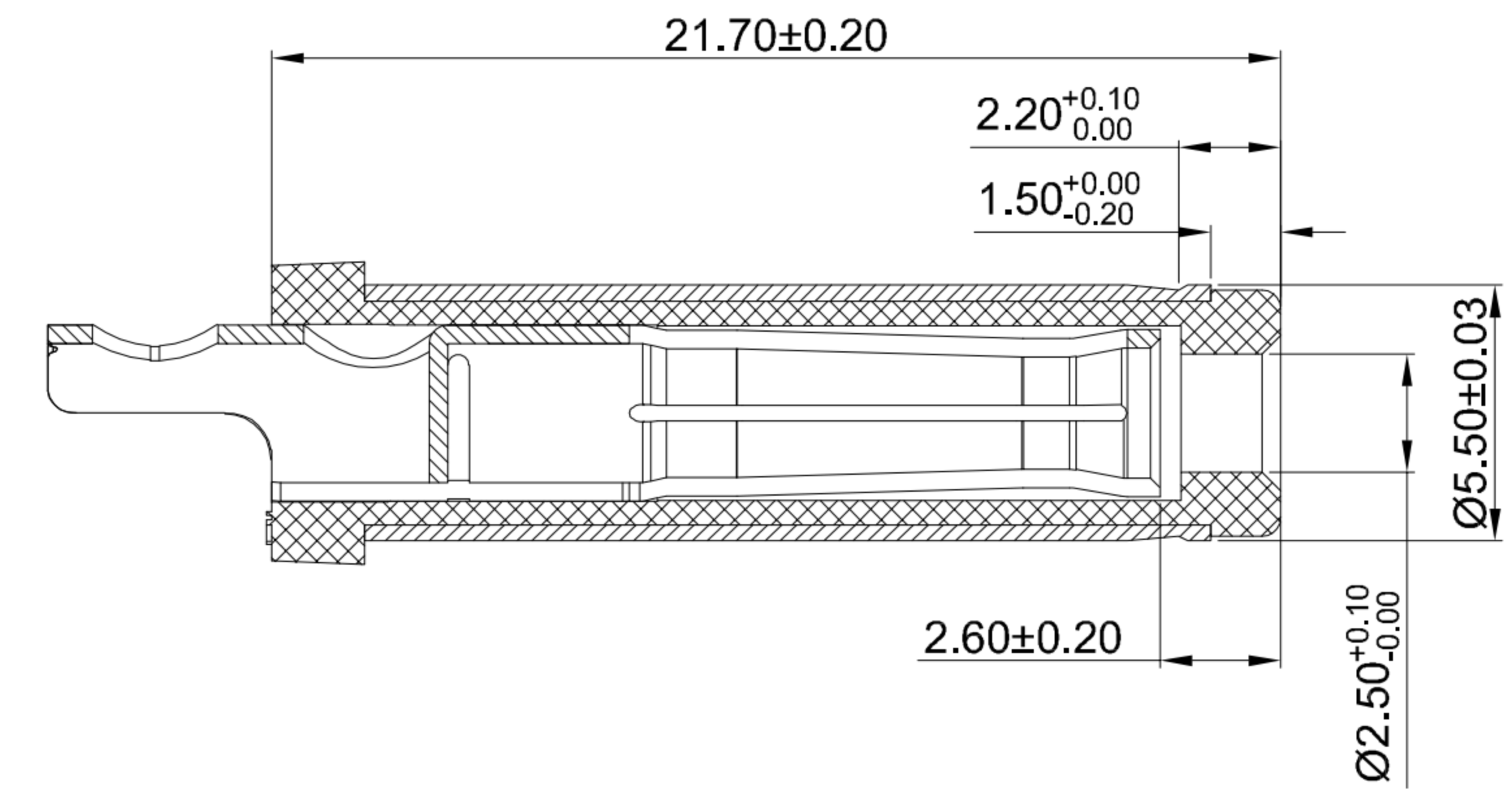

MATING PLUG Ø5.5xØ2.5mm

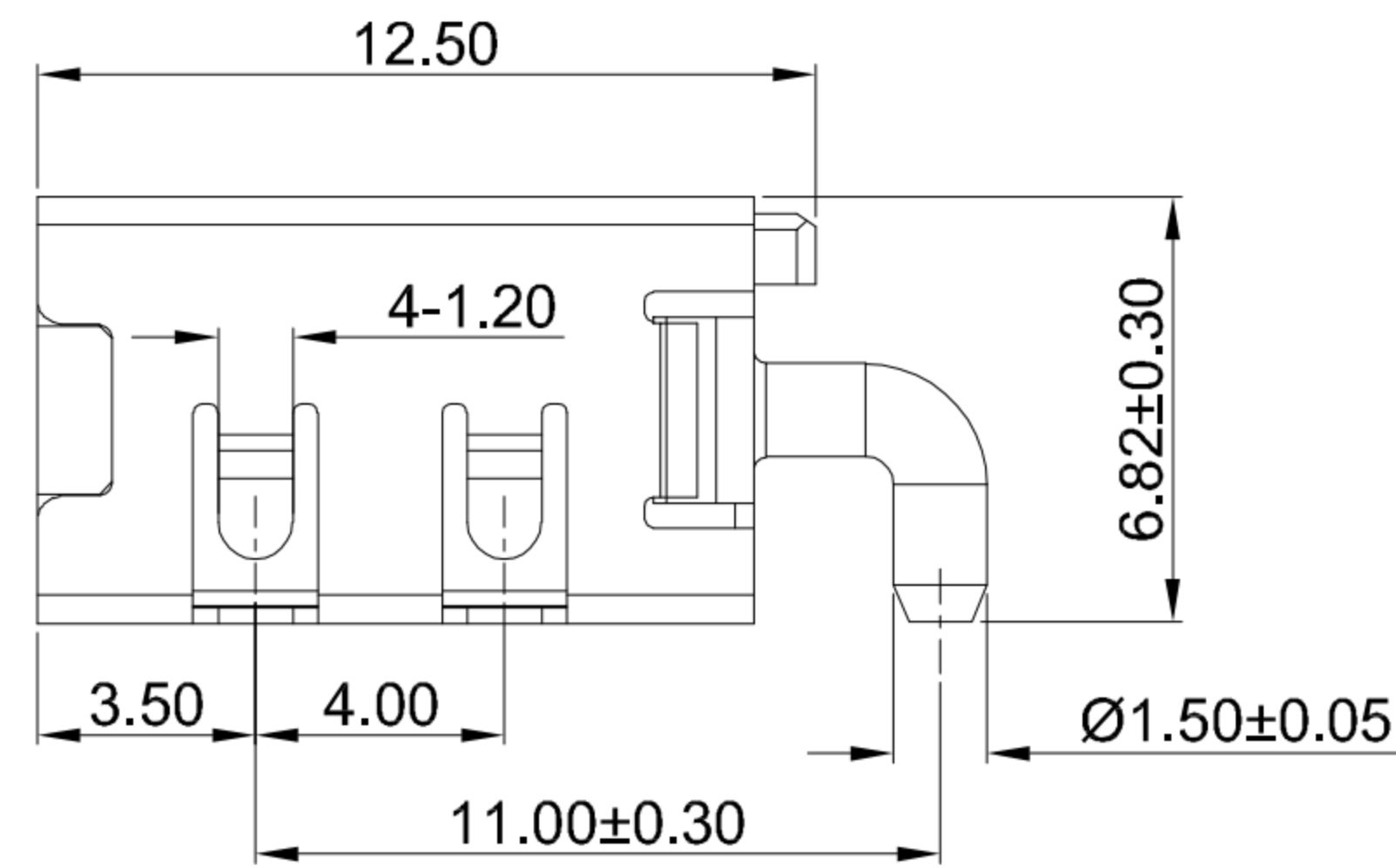
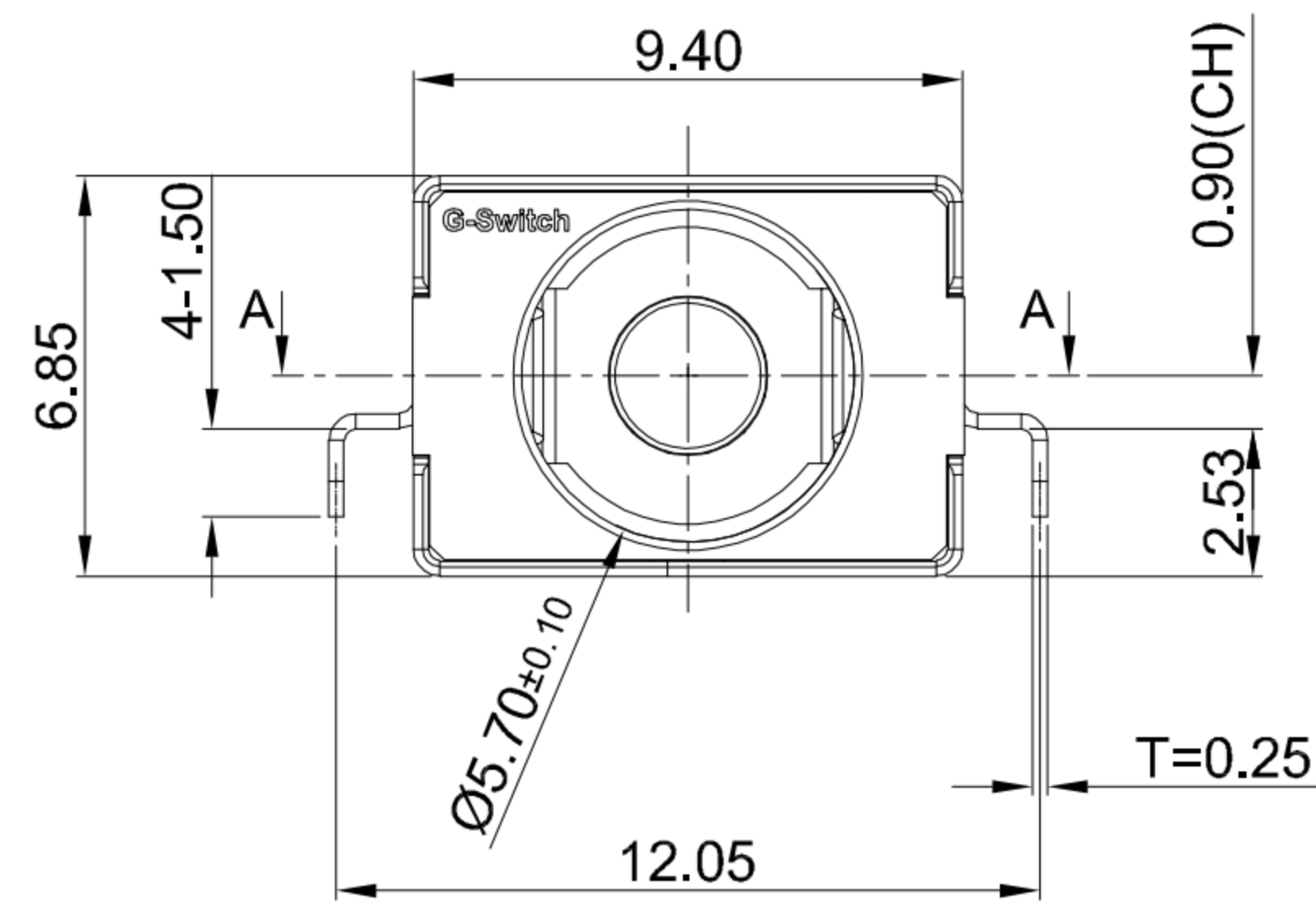
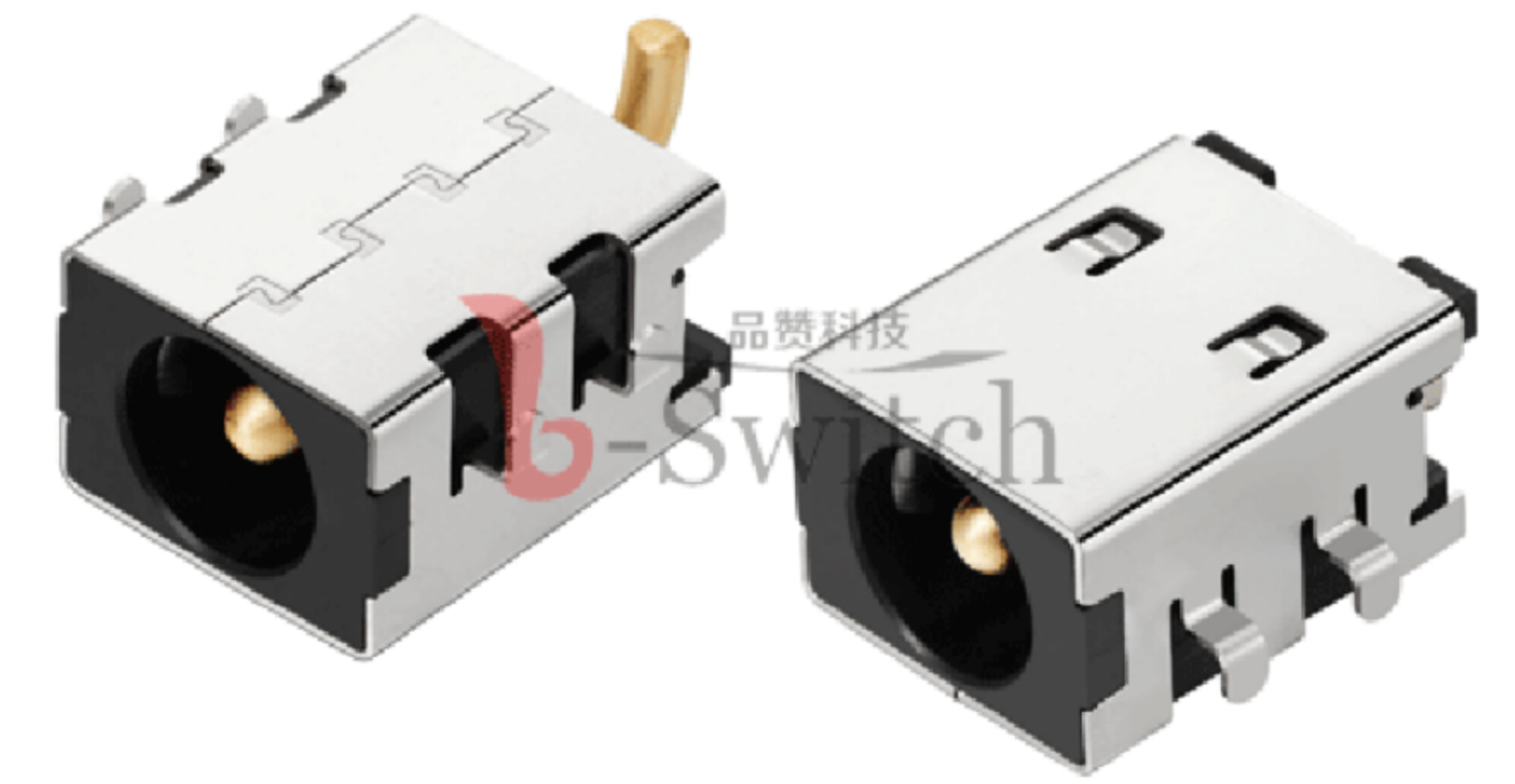
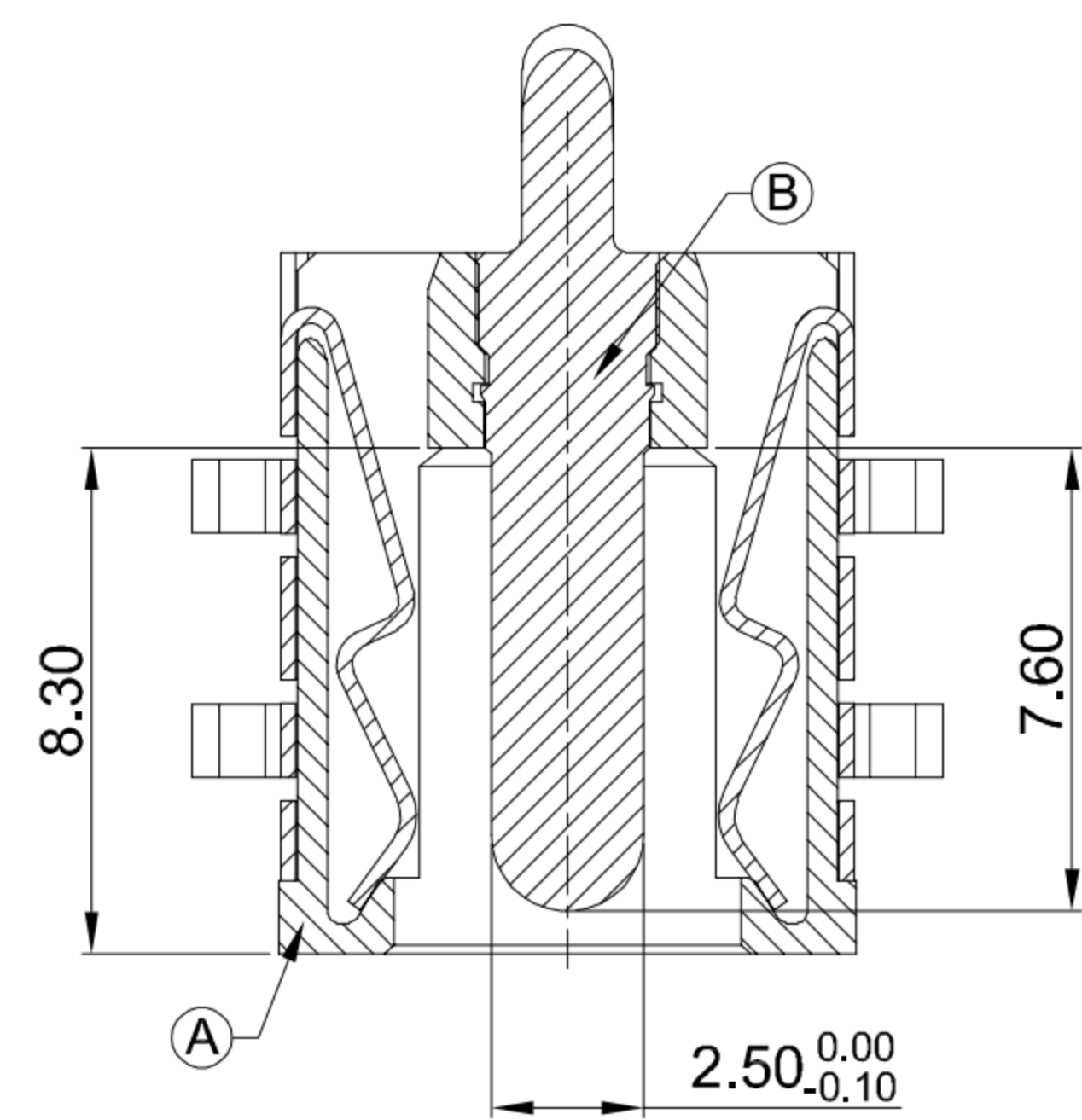

SECTION A-A

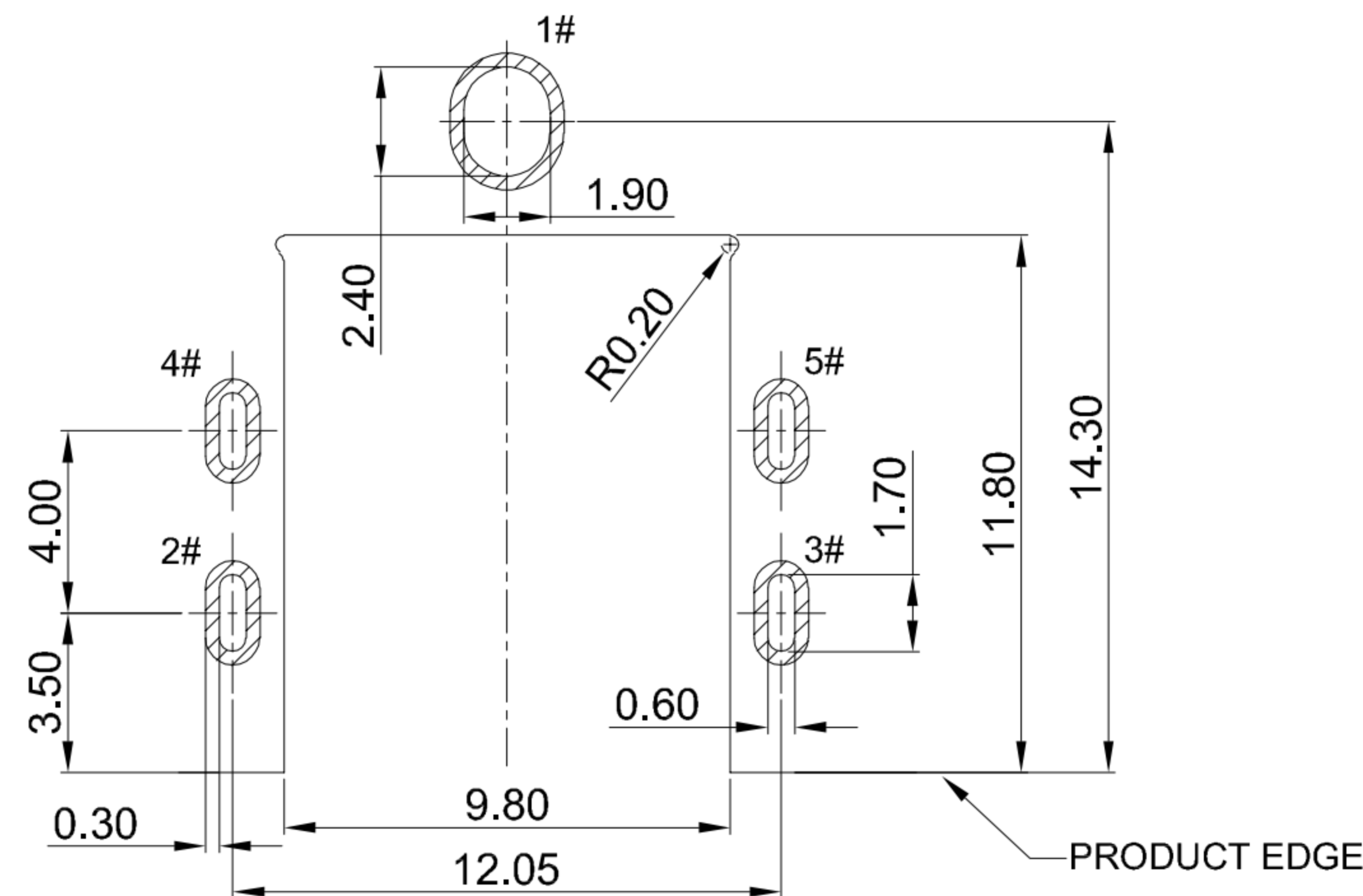

RECOMMENDED PCB LAYOUT
TOLERANCE:±0.05

G-Switch Specification:

1. Operating temperature range: -40°C ~ +85°C
2. Rated load: 15A.30V DC
3. Insulation resistance: 100MΩ min
4. Withstand voltage: 500V AC/min
5. Contact resistance: 30mΩ max
6. Durability cycle: 5,000 Cycles
7. Insertion and extraction force: 3-30N

A	HOUSING	HIGH TEMPERATURE PLASTIC	PA10T BLACK
B	CENTER PIN	BRASS	GOLD FLASH/Ni
C	SHELL	C5210	Ni PLATING
NO.	PART NAME	MATERIAL	REMARK



SCALE: 1:1 UNIT: mm
SIZE: A4

Title: Horizontal DC Power Jack 5525
DIP Sink2.53 CH=0.9 L=12.5 Ø2.5mm

Unless otherwise
General tolerance:
X ±0.50
X.x ±0.30
X.xx ±0.20
X.xxx ±0.10
X.x° ±3°

Molde Code: DC-S007C-D025-15A

DRAWN	CHECKED	APPROVED	DATE
Xia	Chen	Chen	2023.02.01



REV: A0 SHEET: 1/1