

1

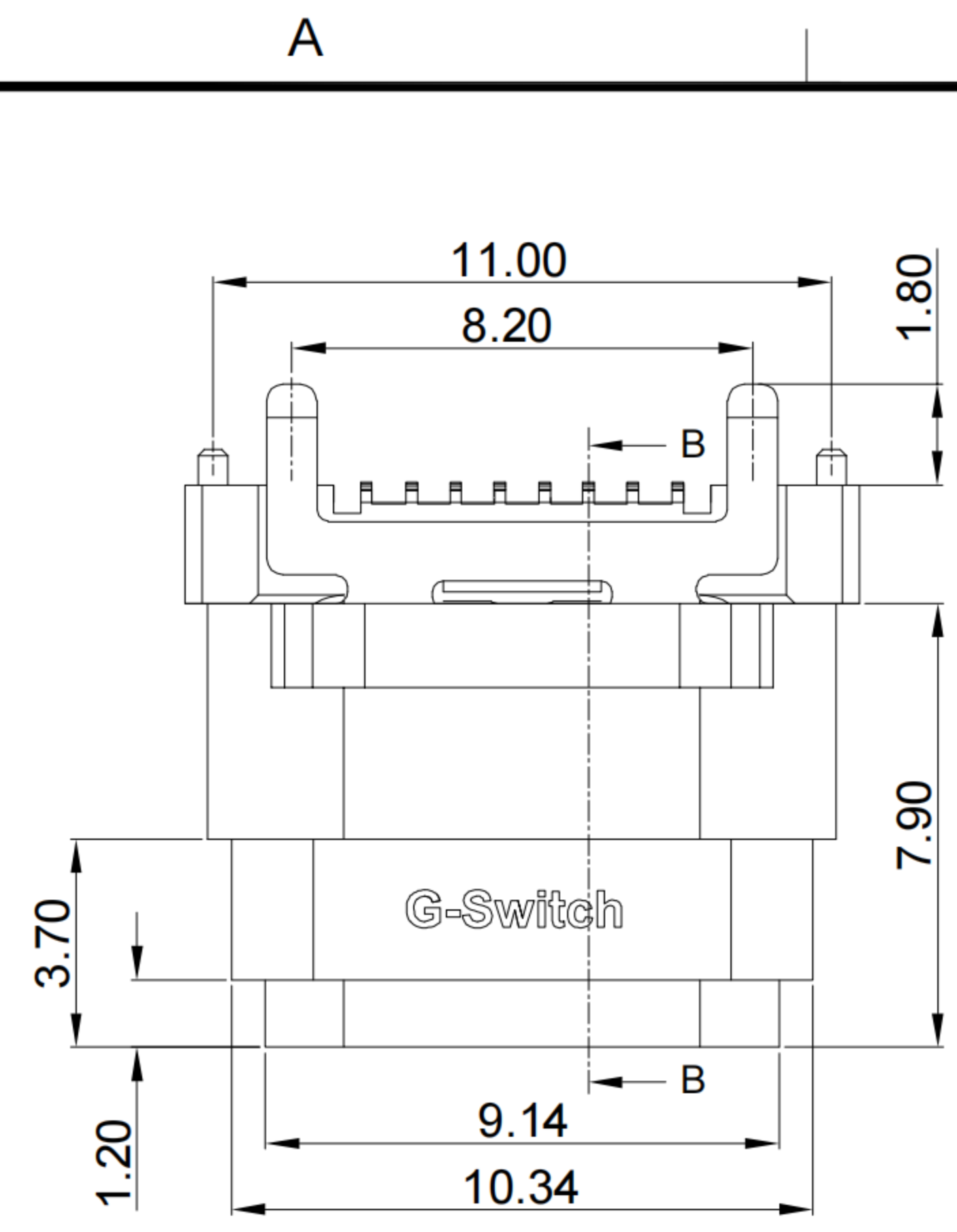

B

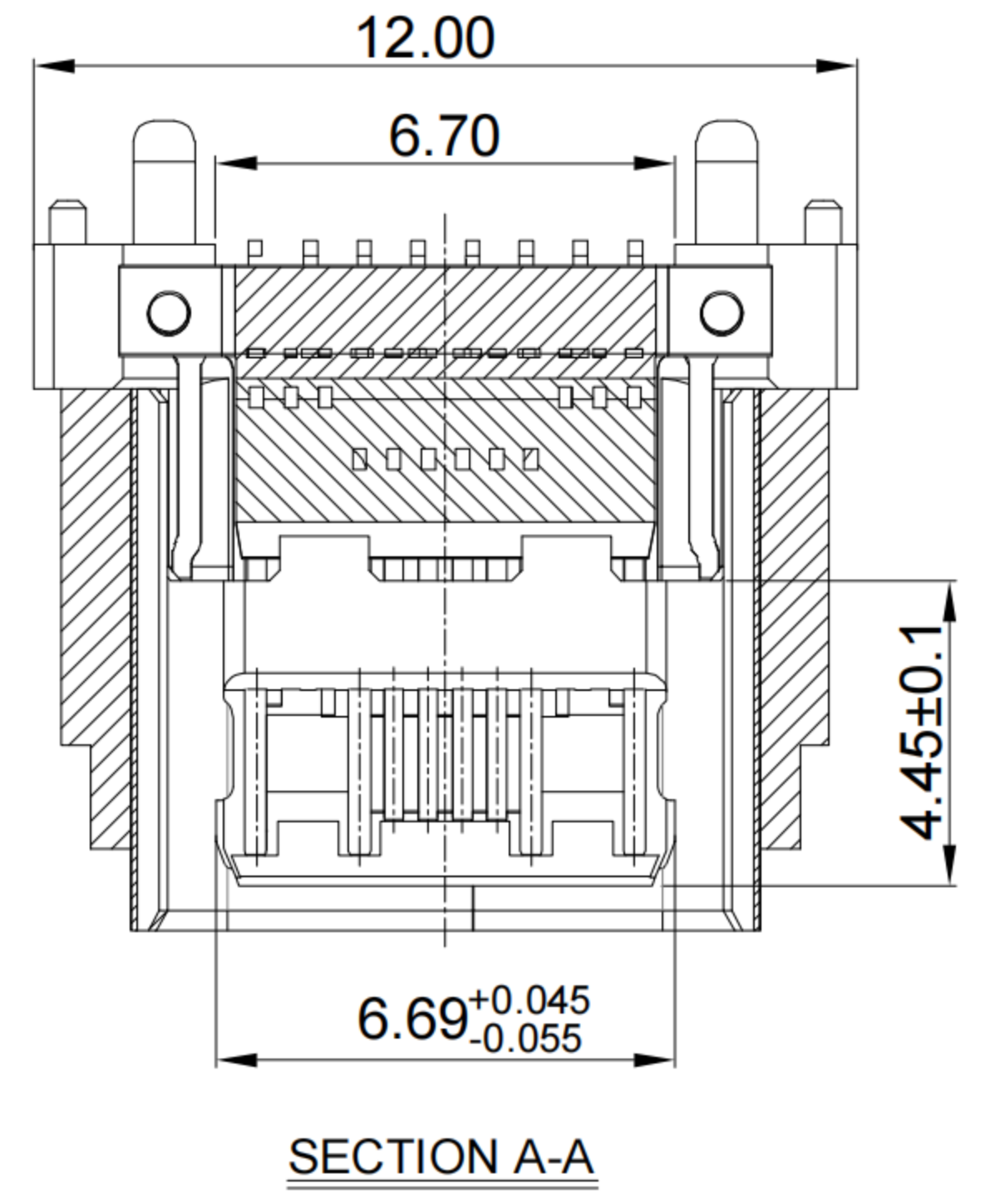

C

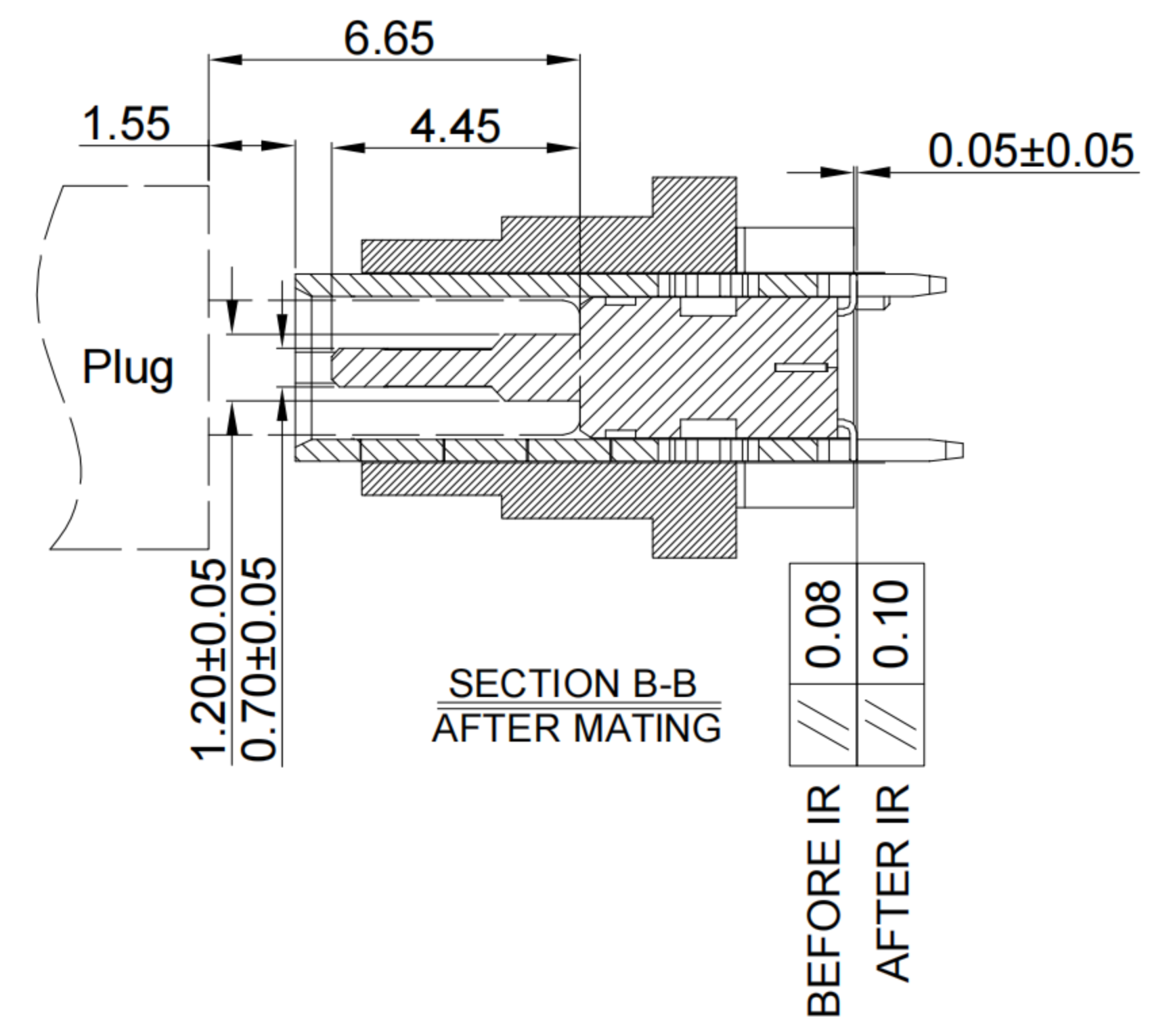

D



E

2

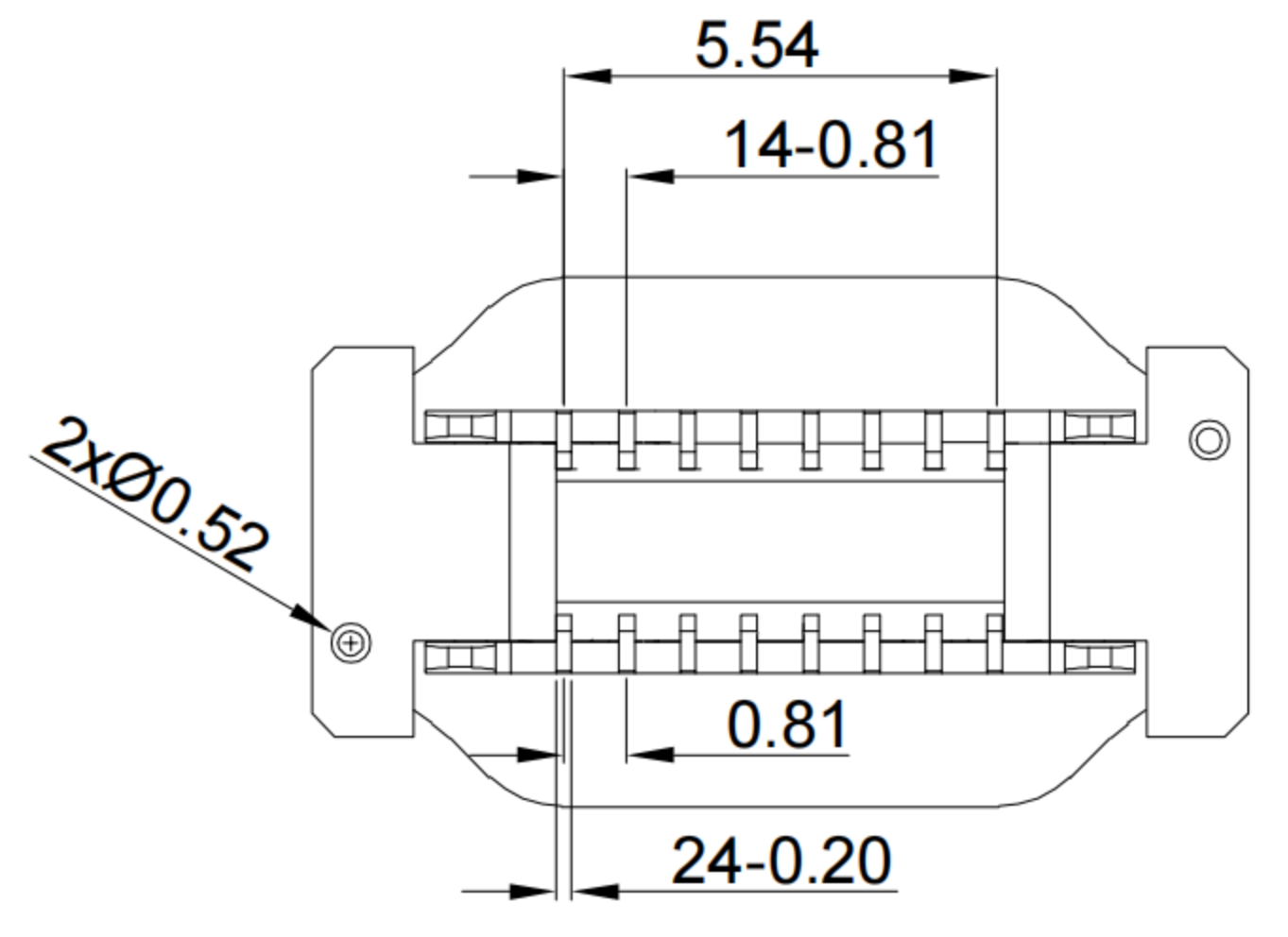
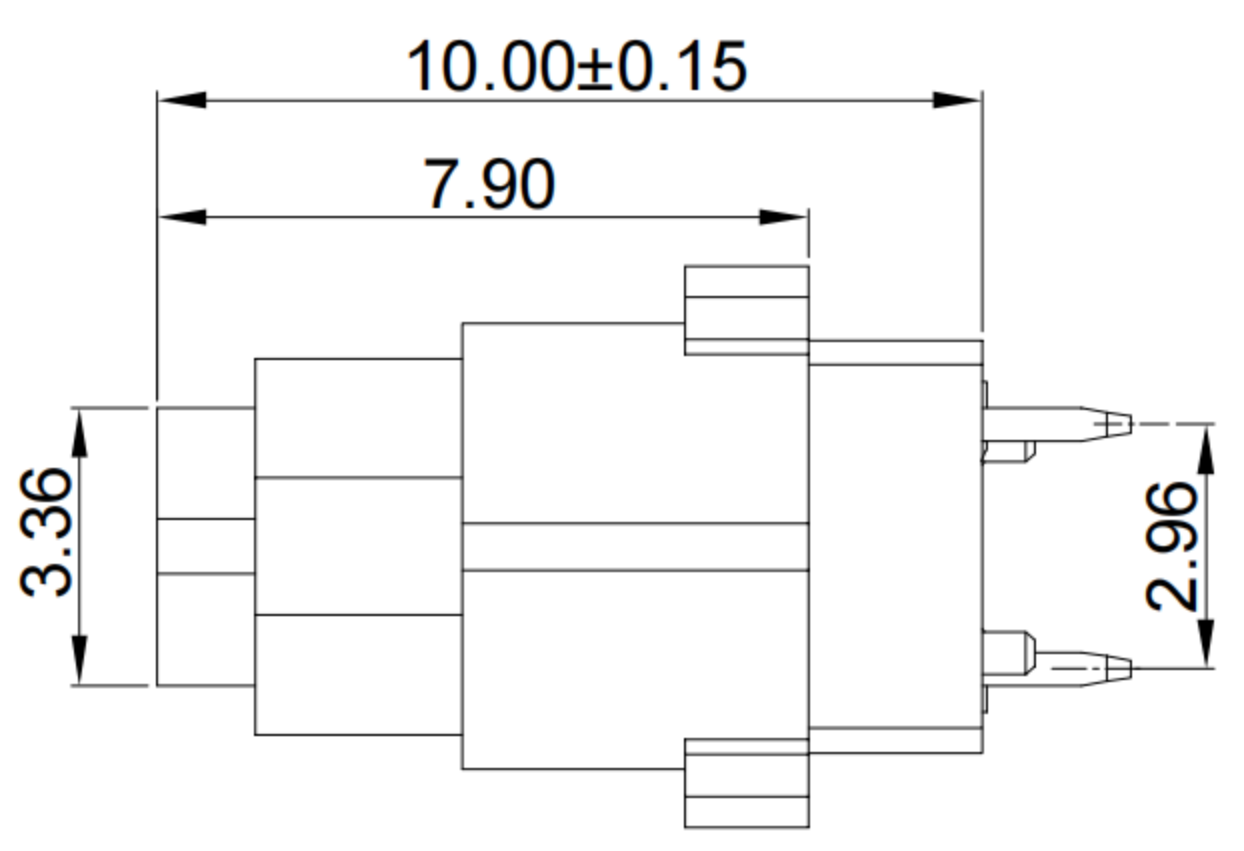
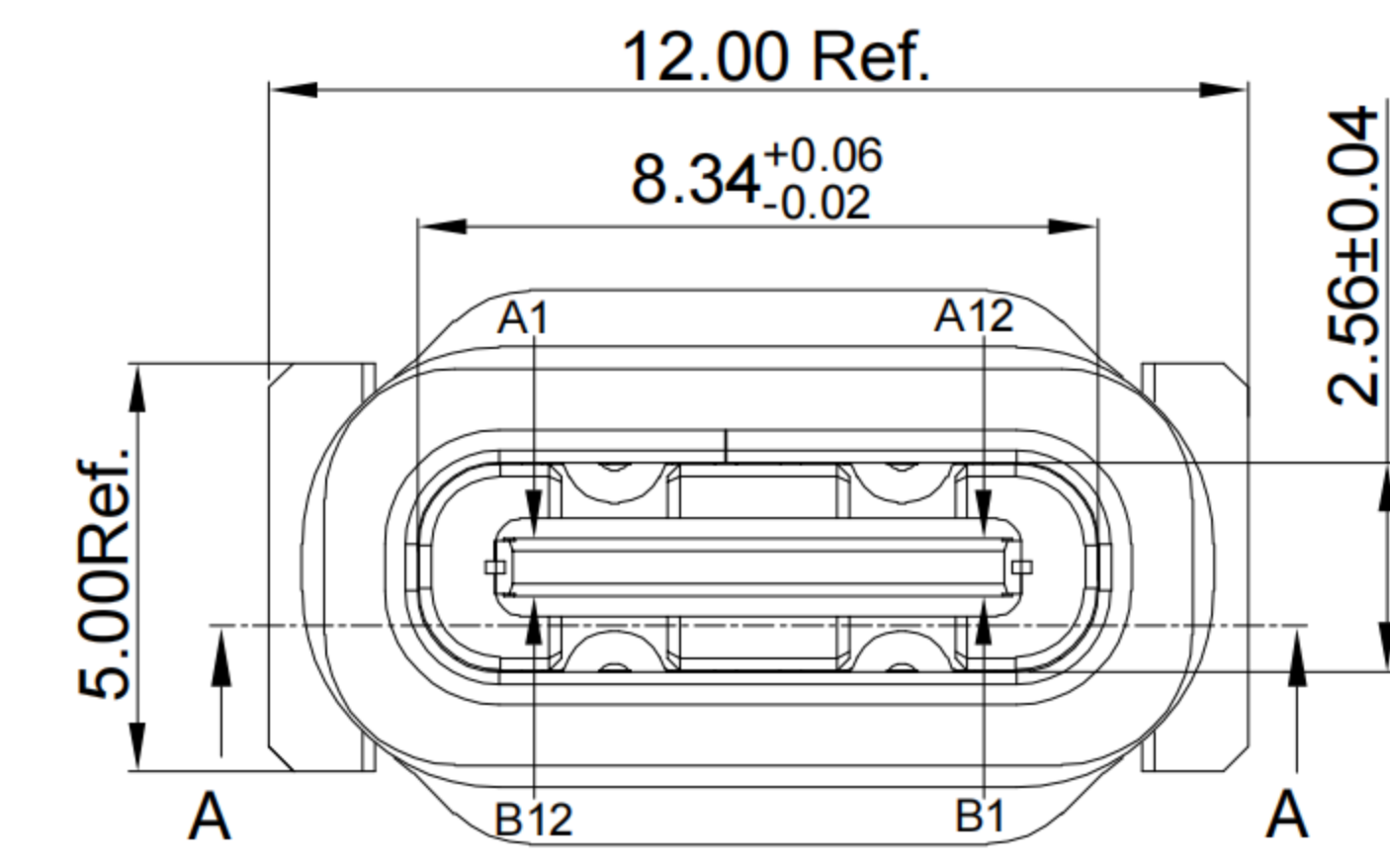

3

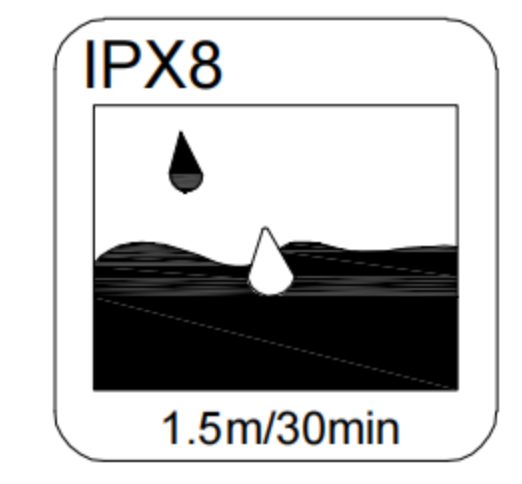
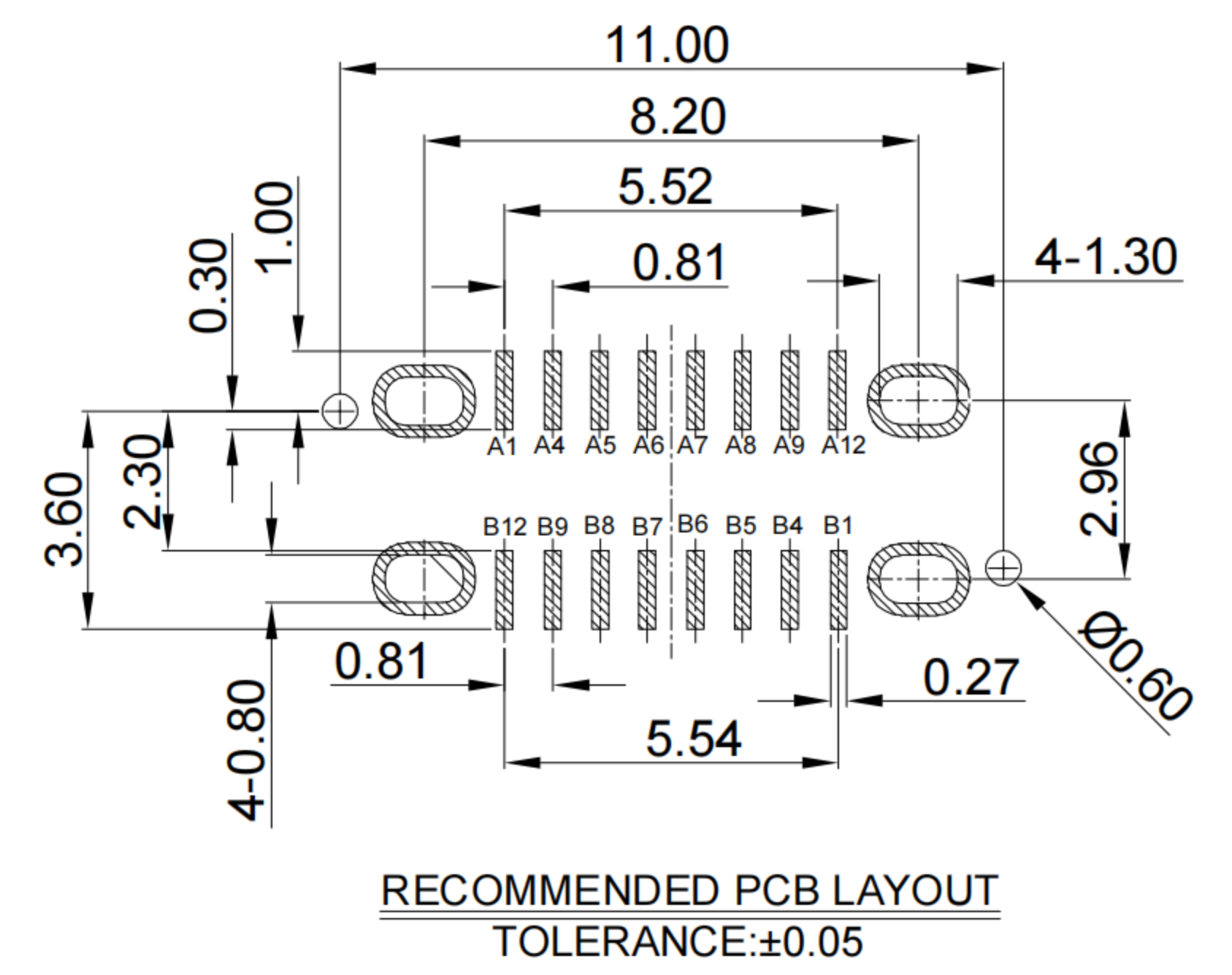
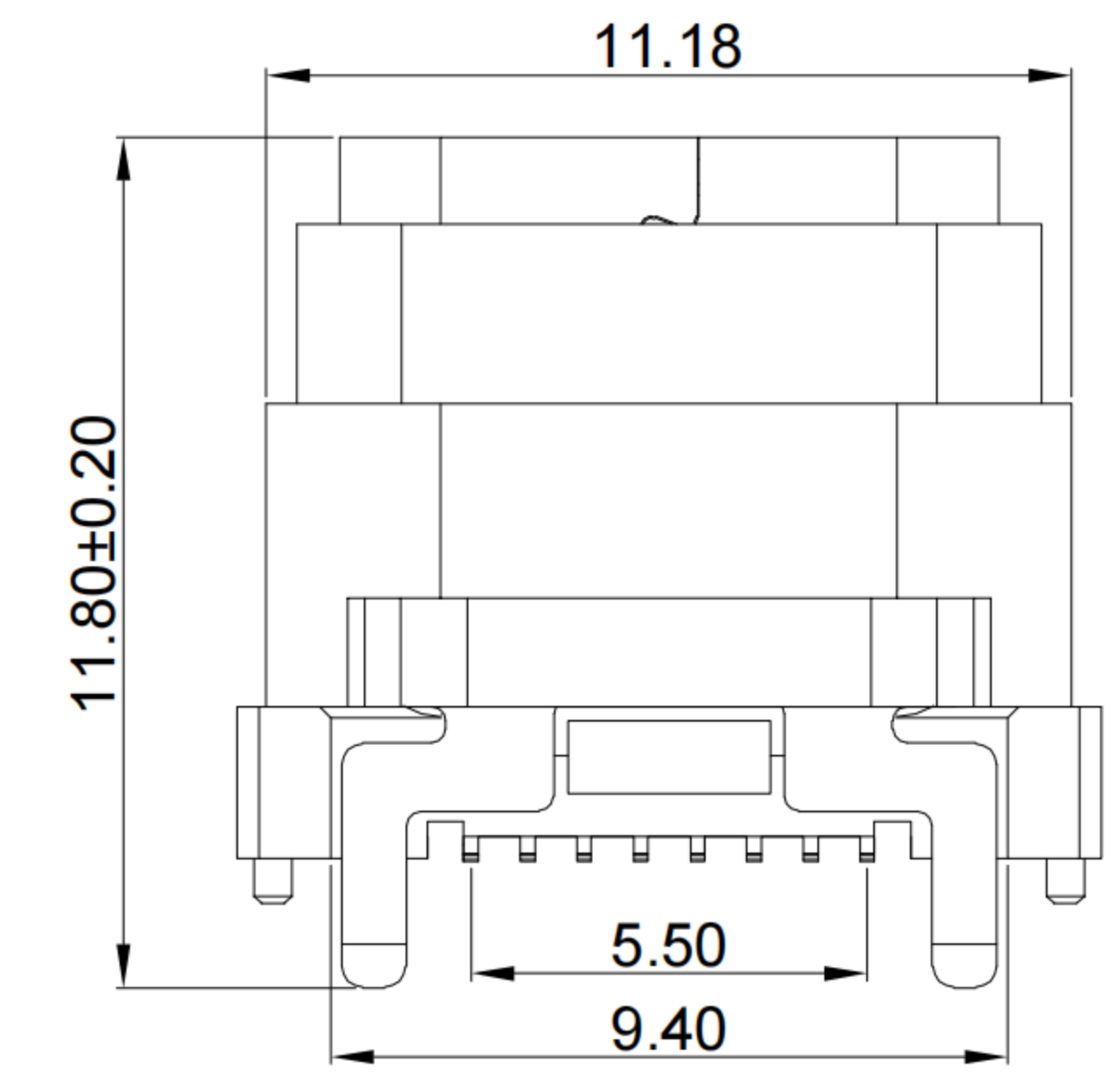

**G-Switch USB-C Specification:**

- Current rated: 5A on vbus/1.25A on vconn/0.25A on other  
Voltage rating: 24V AC
- Withstanding voltage: 100V AC/minute
- Contact resistance: 40mΩ Max
- Insulation resistance: 100MΩ Min
- Operating temperature: -40°C ~ +85°C
- Mating force: 5N~20N
- Unmating force: 8N~20N
- Durability cycle: 10,000 cycles
- Waterproof grade: IP-X8

A1	A2	A3	A4	A5	A6	A7	A8	A9	A10	A11	A12
GND			VBUS	CC1	D+	D-	SBU1	VBUS			GND
First			First	Second	Second	Second	Second	First			First
B12	B11	B10	B9	B8	B7	B6	B5	B4	B3	B2	B1
GND			VBUS	SBU2	D-	D+	CC2	VBUS			GND
First			First	Second	Second	Second	Second	First			First

4

1	CAP	HIGH TEMPERATURE PLASTIC	BLACK
2	SHELL	STAINLESS STEEL	NI PLATED
3	MID PLATE	STAINLESS STEEL	--
4	HOUSING	HIGH TEMPERATURE PLASTIC	Black UL 94 V-0
5	TERMINALS	COPPER ALLOY	Au PLATING ON CONTACT AREA
NO.	PARTS	MATERIAL	REMARKS



SCALE: 1:1 UNIT: mm  
 SIZE: A4

Unless otherwise  
 General Tolerance:  
 X.x ±0.30  
 X.xx ±0.20  
 X.xxx ±0.10  
 X.x° ±3°  
 X.xx° ±2°

Title: Vertical Type-c 16P Female  
 SMT H=10.0mm

Molde Code: GT-USB-7096DB

DRAWN	CHECKED	APPROVED	DATE
Xia	Chen	Chen	2023.02.01



REV: A0 SHEET: 1/2

5



1

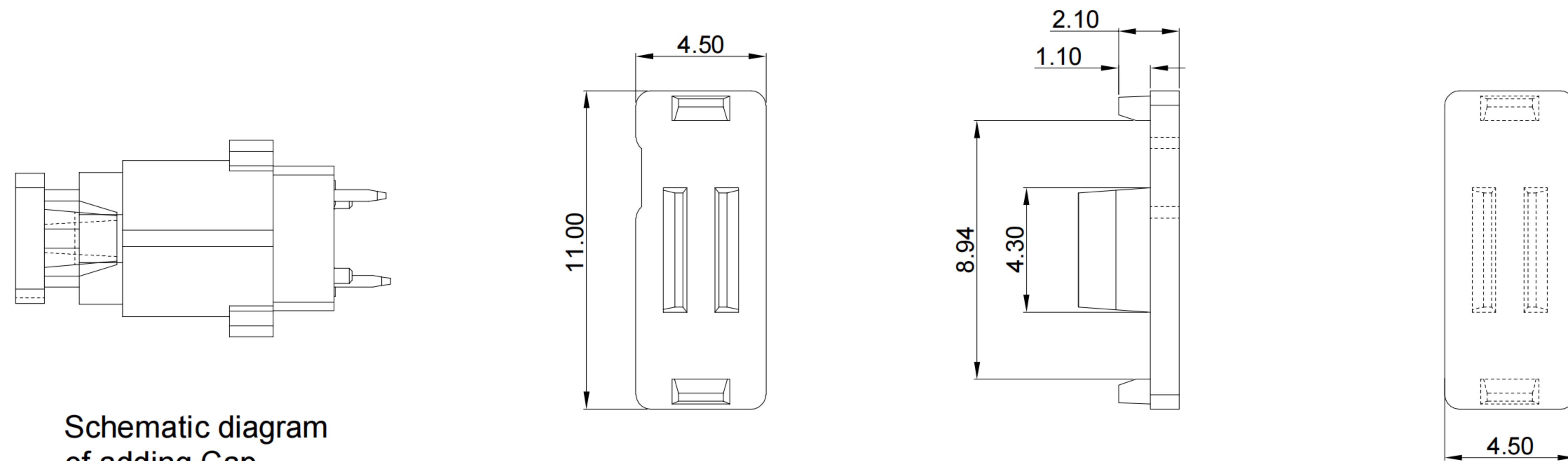

Schematic diagram of adding Cap

2



3

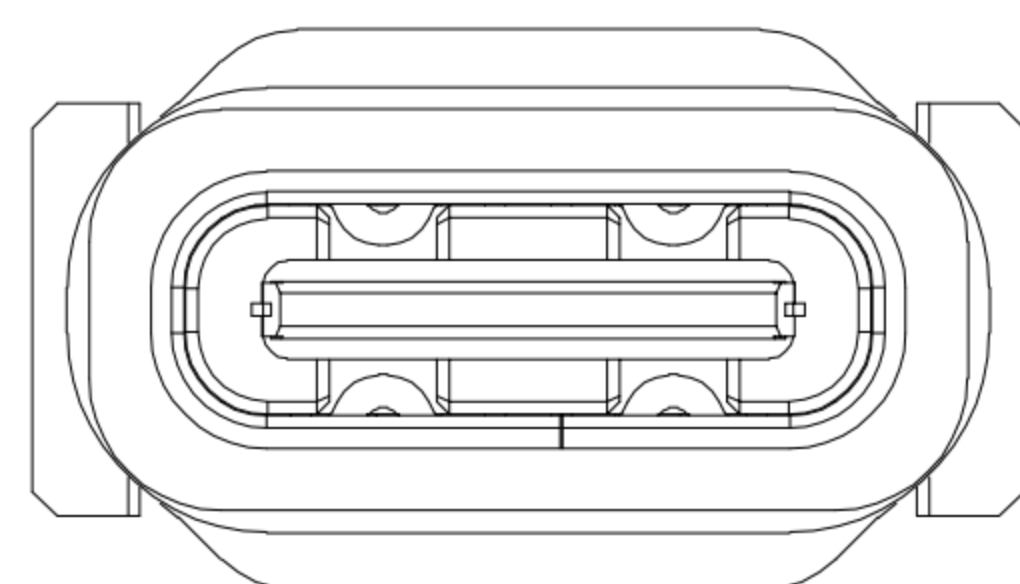

4

Schematic diagram of adding water-proof ring

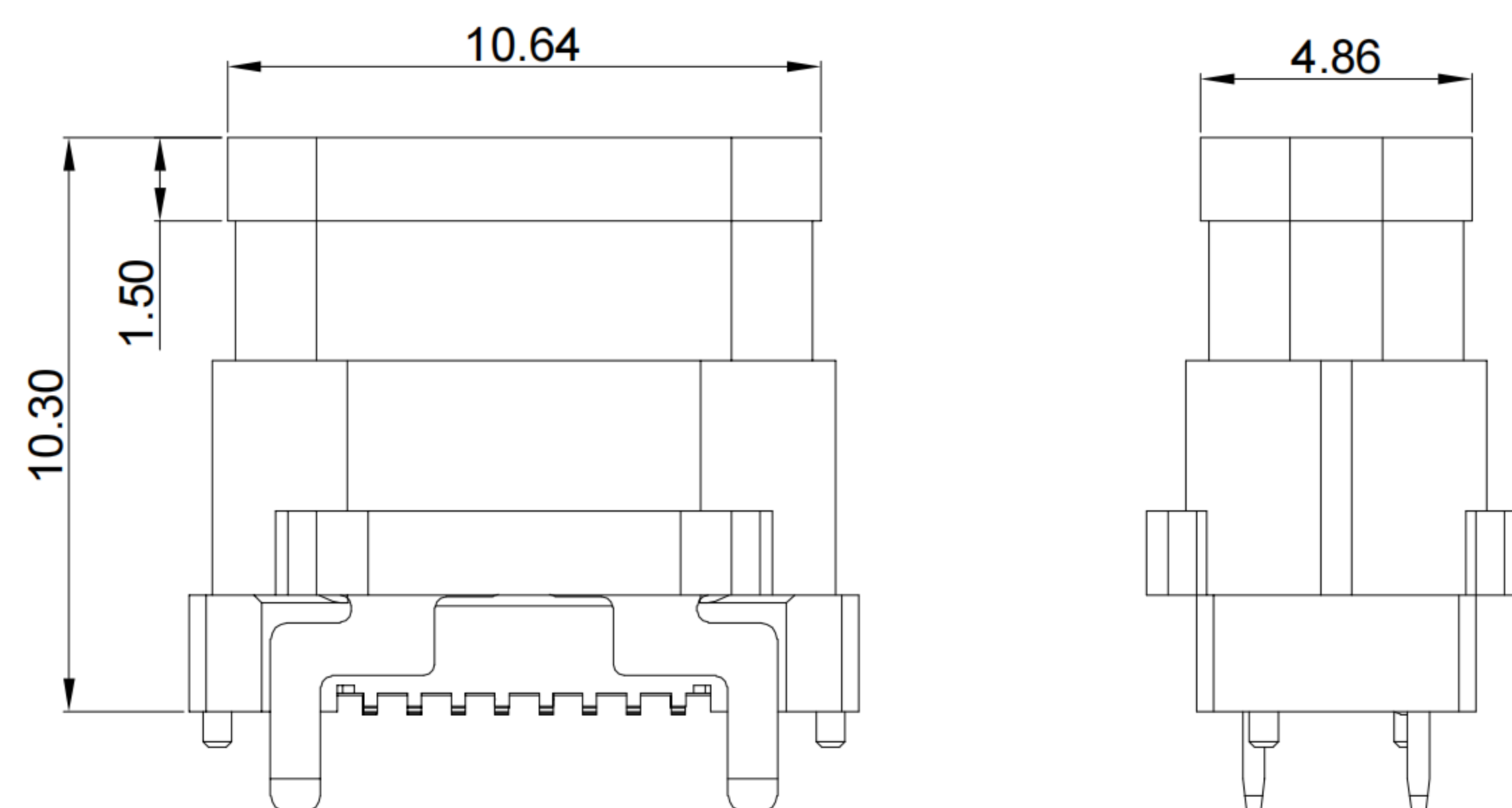

5



**G-Switch USB-C Specification:**

- 1.Current rated: 5A on vbus/1.25A on vconn/0.25A on other  
Voltage rating: 24V AC
- 2.Withstanding voltage: 100V AC/minute
- 3.Contact resistance: 40mΩ Max
- 4.Insulation resistance: 100MΩ Min
- 5.Operating temperature: -40°C ~ +85°C
- 6.Mating force: 5N~20N
- 7.Unmating force: 8N~20N
- 8.Durability cycle: 10,000 cycles
- 9.Waterproof grade: IP-X8

A1	A2	A3	A4	A5	A6	A7	A8	A9	A10	A11	A12
GND			VBUS	CC1	D+	D-	SBU1	VBUS			GND
First			First	Second	Second	Second	Second	First			First
B12	B11	B10	B9	B8	B7	B6	B5	B4	B3	B2	B1
GND			VBUS	SBU2	D-	D+	CC2	VBUS			GND
First			First	Second	Second	Second	Second	First			First

SCALE: 1:1	UNIT: mm	Title: Vertical Type-c 16P Female SMT H=10.0mm	
SIZE: A4		Title: Vertical Type-c 16P Female SMT H=10.0mm	
Unless otherwise General Tolerance: X.x ±0.30 X.xx ±0.20 X.xxx ±0.10 X.x° ±3° X.xx° ±2°		Molde Code: GT-USB-7096DB	
DRAWN	CHECKED	APPROVED	DATE
Xia	Chen	Chen	2023.02.01
REV: A0		SHEET: 2/2	

