

SECTION:A-A

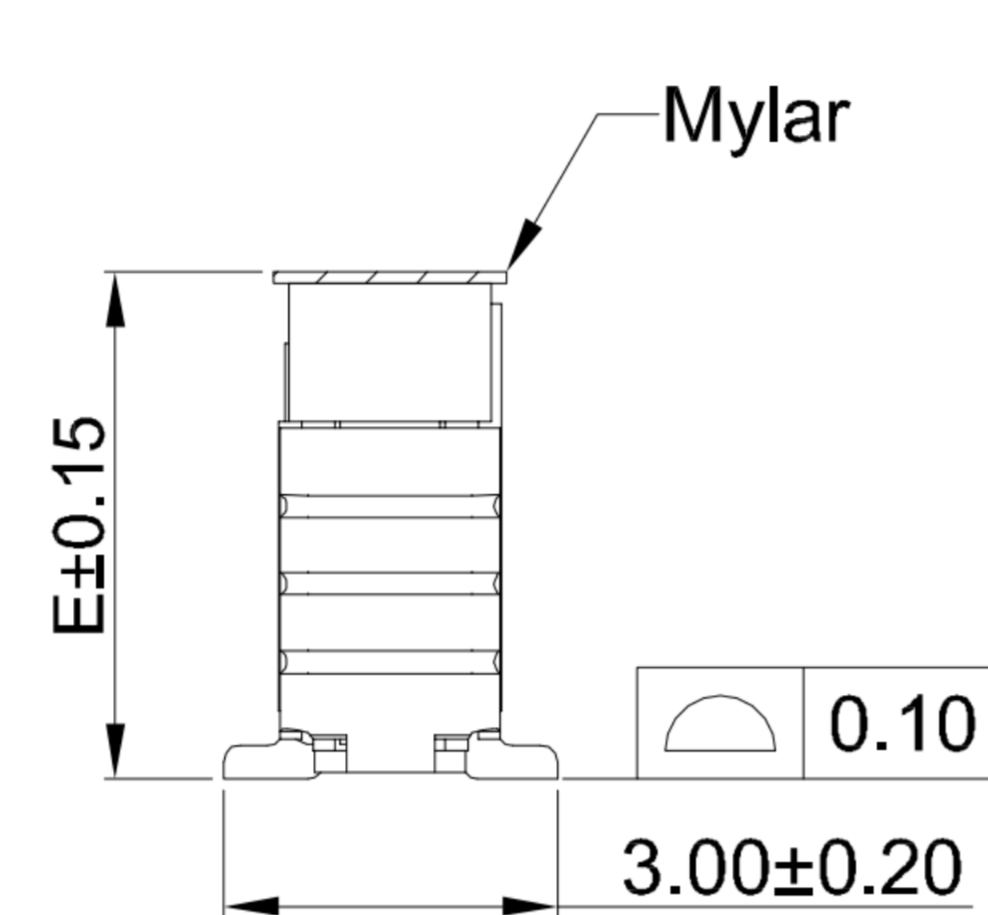

4PIN-5PIN MYLAY

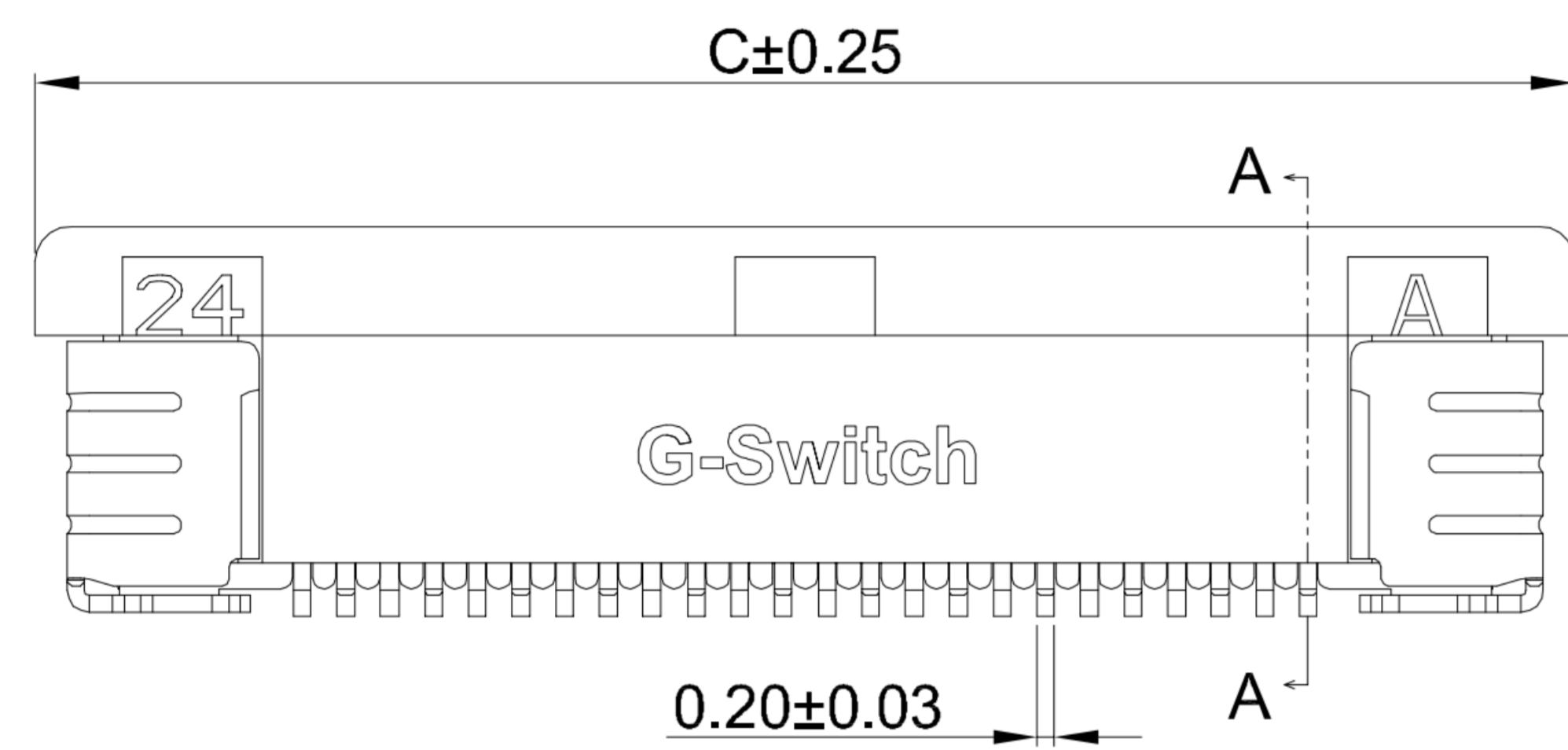
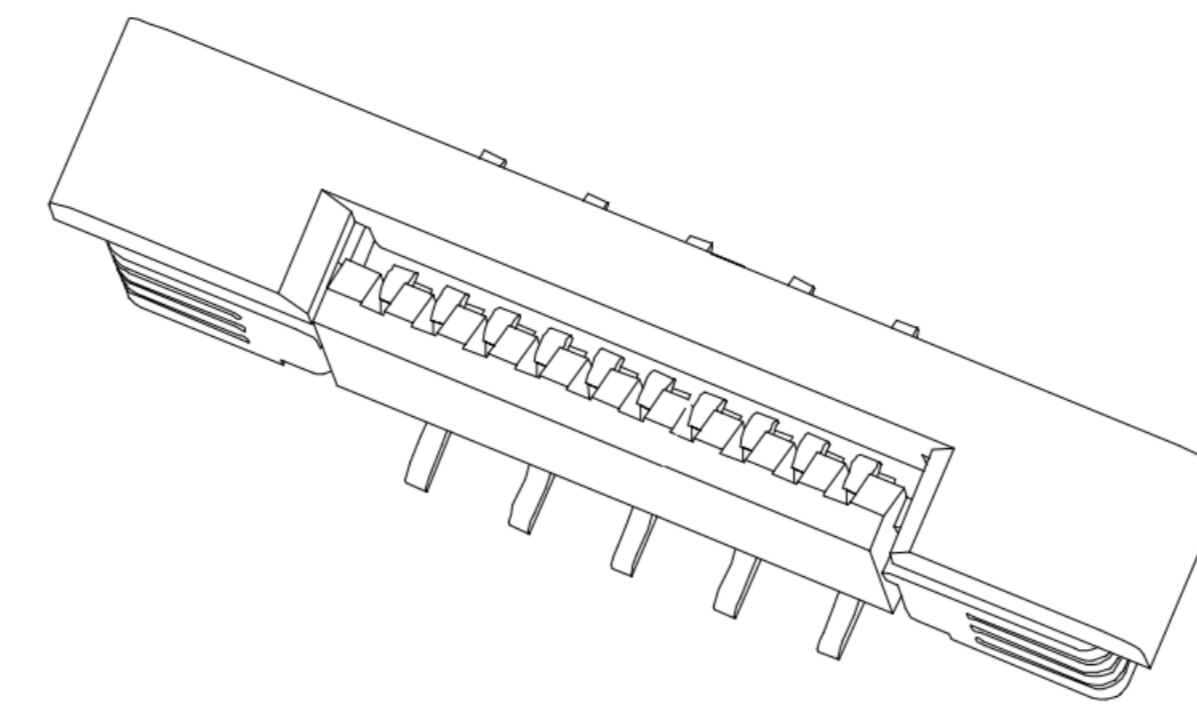
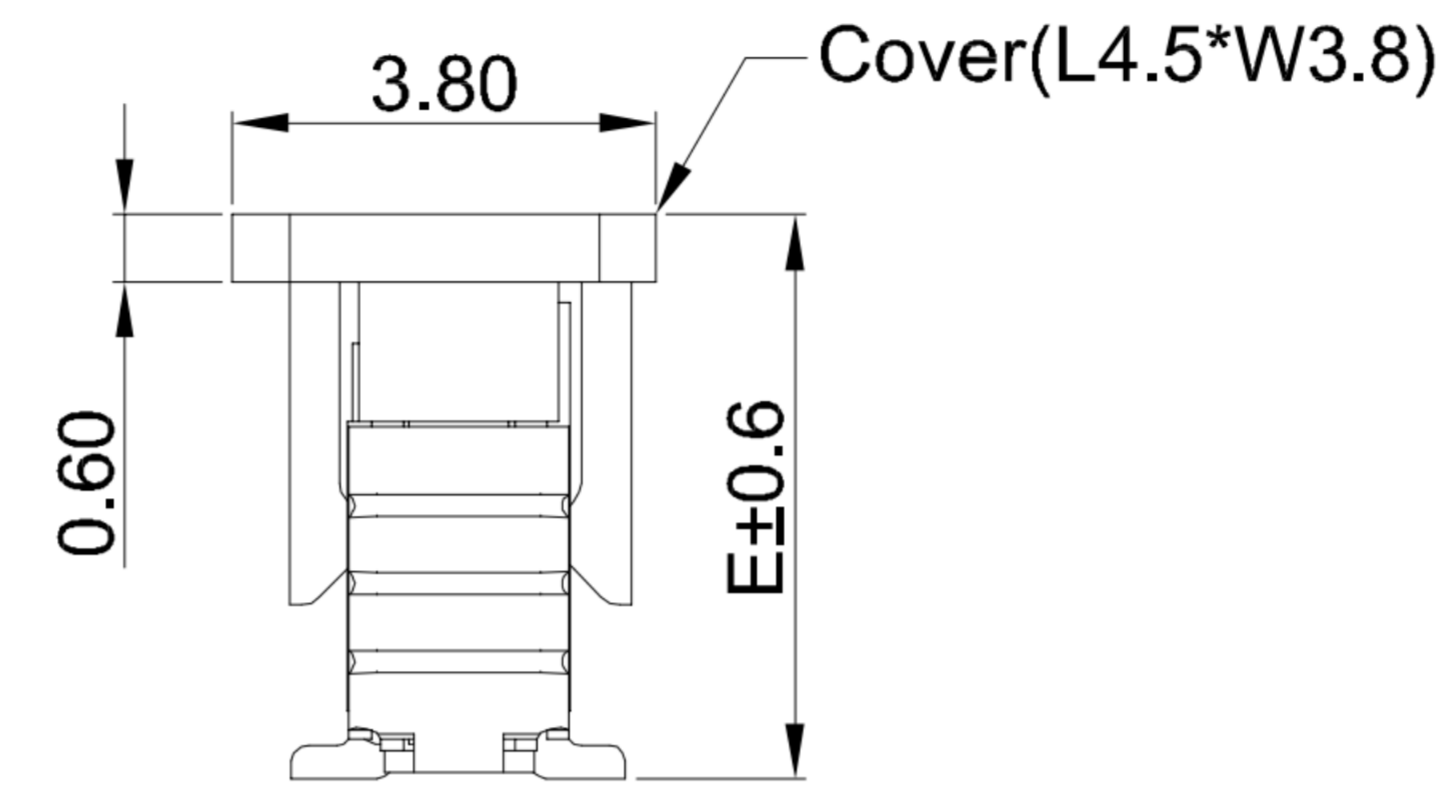

6PIN-60PIN WITH COVER

GT-F0504 S V 45 -XX X XX 02

G-Switch

Series No

Termipoint  
S-SMT

Angle  
V-180°

Height  
45-4.45mm

Contact  
01-A Type  
(Bottom Contacts)  
02-B Type  
(Top Contacts)

Terminal Plating  
11-All G/F  
MT-Matte Tin

Housing Colour  
S-Nature

Pin Q' PY  
04~60

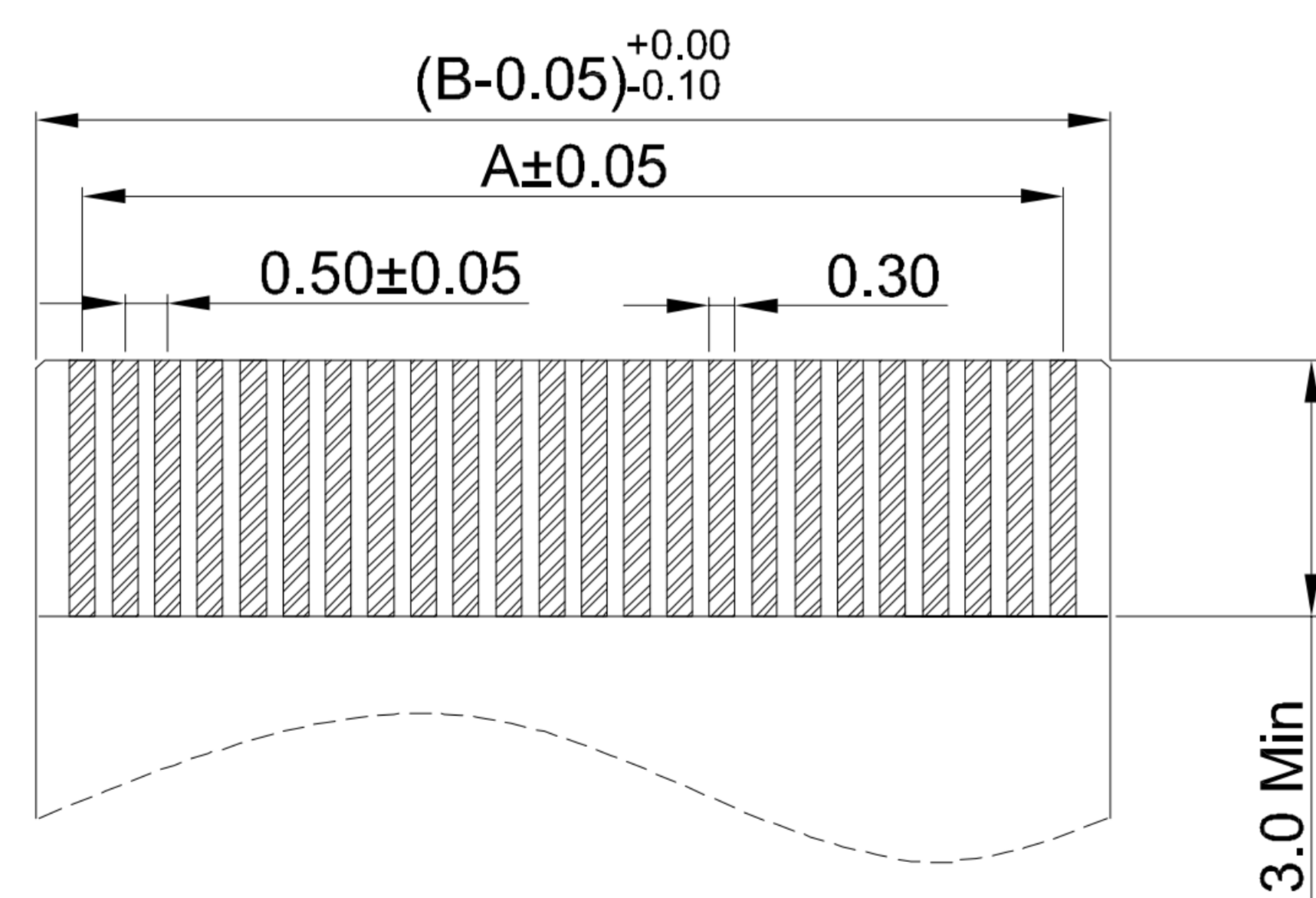
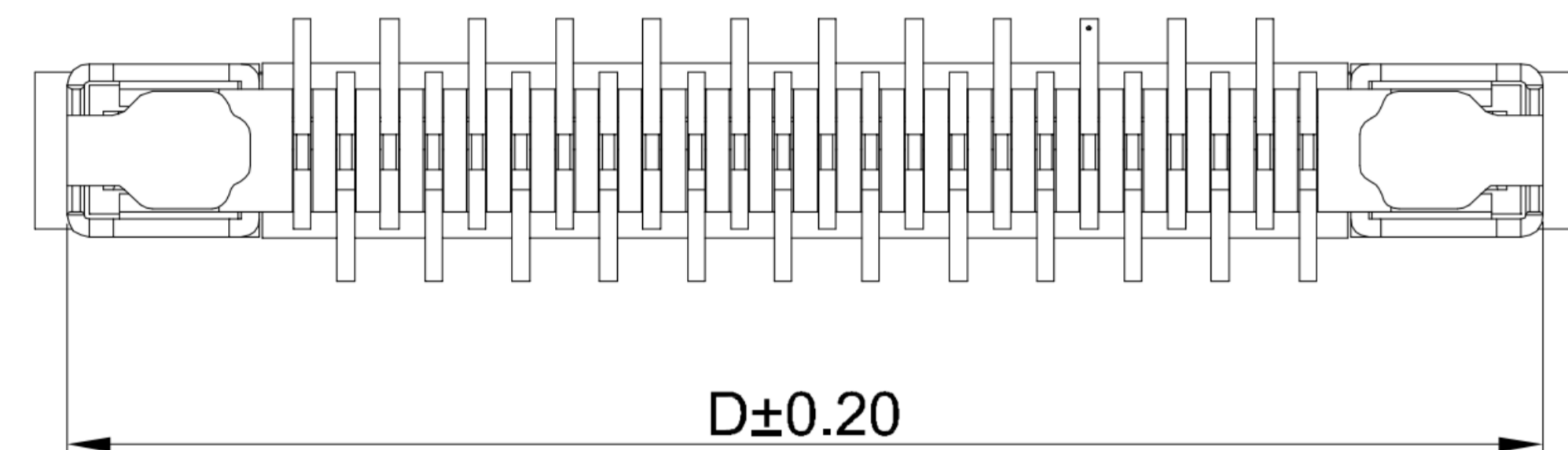

APPLICABLE FPC

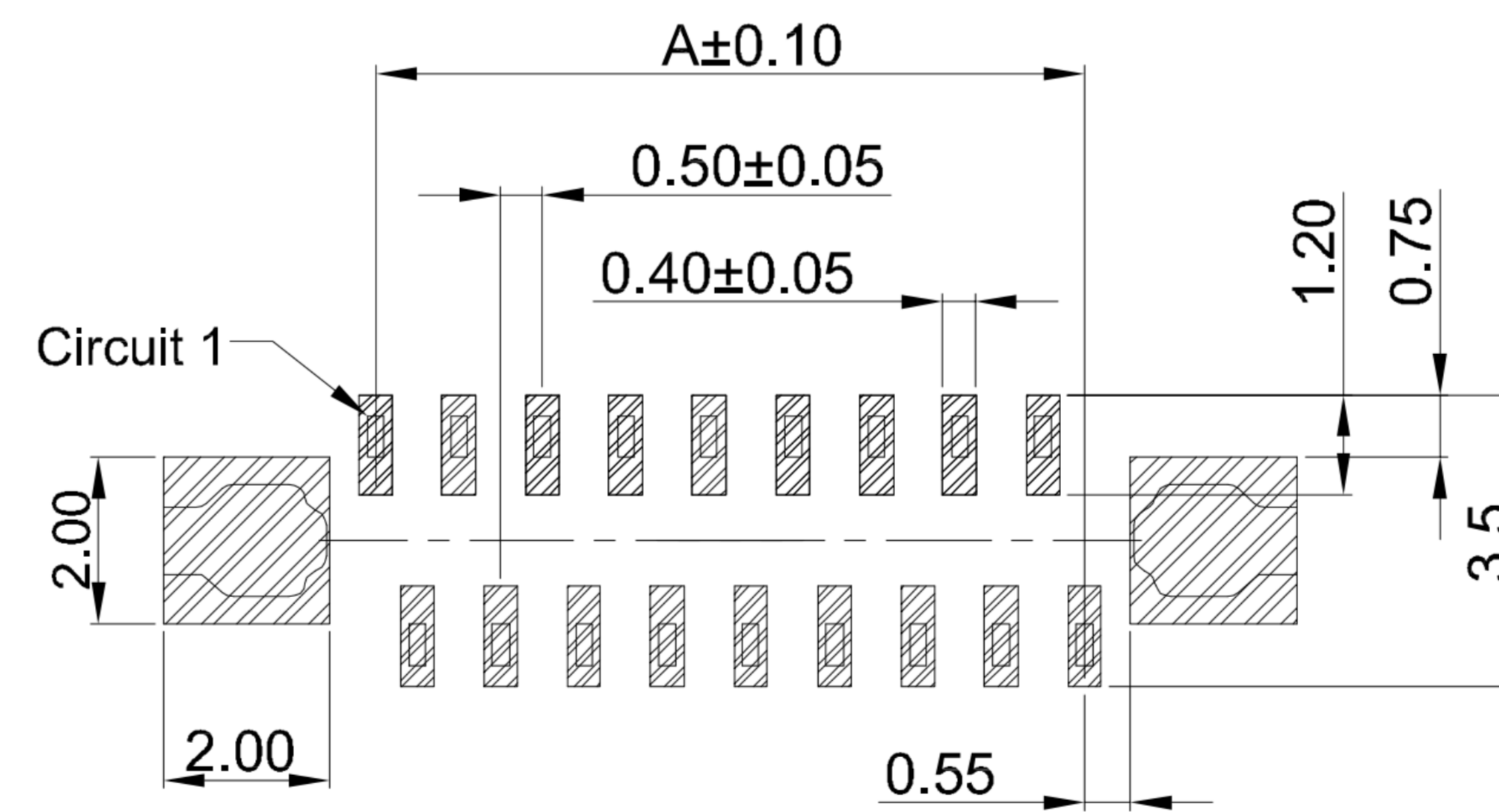
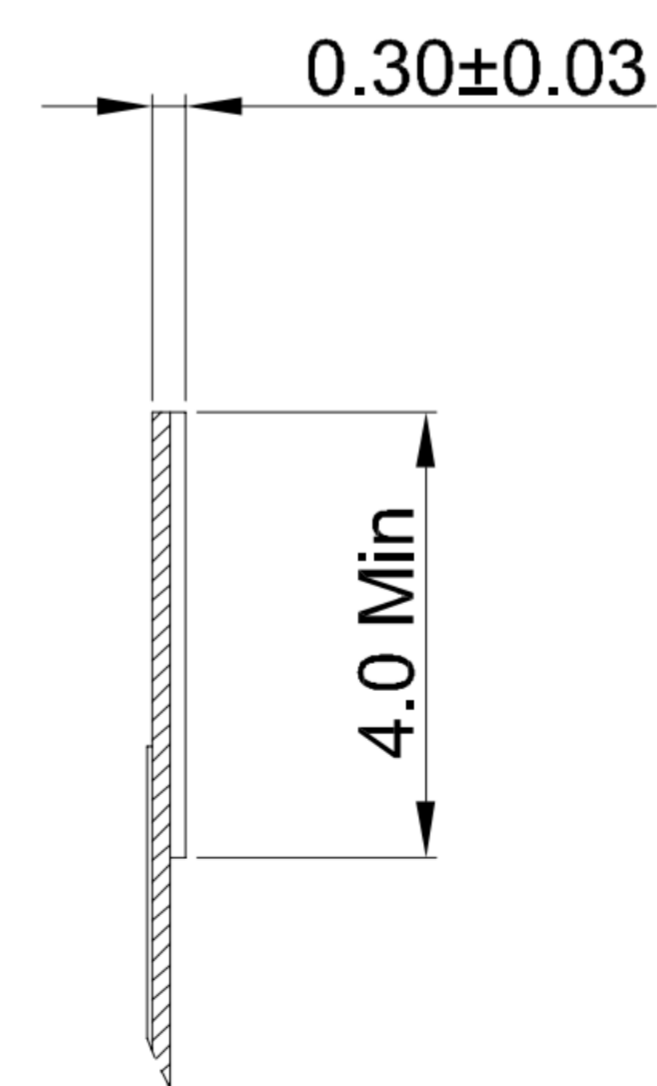

RECOMMENDED PCB LAYOUT  
TOLERANCE:±0.05

**G-Switch Specification:**

- 1.Current rated: 0.5A AC/DC
- 2.Voltage rating: 50V AC/DC
- 3.Withstanding voltage: 250V AC
- 4.Contact resistance: 30mΩ max.
- 5.Insulation resistance: 100MΩ min
- 6.Durability cycle: 30Cycles
- 7.Removal force: 0.04kgf/Pin min
- 8.Operating temperature range: -55°C ~ +85°C

4	SOLDER TABS	BRASS	MATTE Tin
3	CONTACT	PHOSPHOR BRONZE	Gold-Flash On Contact Area
2	COVER	LCP,94V-0	BLACK
1	HOUSING	LCP,94V-0	NATURE
NO.	PART NAME	MATERIAL	REMARK



SCALE: 1:1 UNIT: mm  
SIZE: A4

Unless otherwise  
General Tolerance:

X ±0.40  
X.x ±0.30  
X.xx ±0.20  
X° ±5°  
X.x° ±3°

Title: FPC 0.50mm Pitch 180° SMT Type  
H4.50mm Connector

Molde Code: GT-F0504SV45-XXXXX02

DRAWN	CHECKED	APPROVED	DATE
Jiang	Hu	Chen	2021.06.28



REV: A0 SHEET: 1/2

Ordering Information:

Circuit	Dimensions(mm)					Circuit	Dimensions(mm)				
	A	B	C	D	E		A	B	C	D	E
04	1.50	2.56	7.60	6.88	4.45	33	16.00	17.06	22.10	21.38	4.45
05	2.00	3.06	8.10	7.38		34	16.50	17.56	22.60	21.88	
06	2.50	3.56	8.60	7.88		35	17.00	18.06	23.10	22.38	
07	3.00	4.06	9.10	8.38		36	17.50	18.56	23.60	22.88	
08	3.50	4.56	9.60	8.88		37	18.00	19.06	24.10	23.38	
09	4.00	5.06	10.10	9.38		38	18.50	19.56	24.60	23.88	
10	4.50	5.56	10.60	9.88		39	19.00	20.06	25.10	24.38	
11	5.00	6.06	11.10	10.38		40	19.50	20.56	25.60	24.88	
12	5.50	6.56	11.60	10.88		41	20.00	21.06	26.10	25.38	
13	6.00	7.06	12.10	11.38		42	20.50	21.56	26.60	25.88	
14	6.50	7.56	12.60	11.88		43	21.00	22.06	27.10	26.38	
15	7.00	8.06	13.10	12.38		44	21.50	22.56	27.60	26.88	
16	7.50	8.56	13.60	12.88		45	22.00	23.06	28.10	27.38	
17	8.00	9.06	14.10	13.38		46	22.50	23.56	28.60	27.88	
18	8.50	9.56	14.60	13.88		47	23.00	24.06	29.10	28.38	
19	9.00	10.06	15.10	14.38		48	23.50	24.56	29.60	28.88	
20	9.50	10.56	15.60	14.88		49	24.00	25.06	30.10	29.38	
21	10.00	11.06	16.10	15.38		50	24.50	25.56	30.60	29.88	
22	10.50	11.56	16.60	15.88		51	25.00	26.06	31.10	30.38	
23	11.00	12.06	17.10	16.38		52	25.50	26.56	31.60	30.88	
24	11.50	12.56	17.60	16.88		53	26.00	27.06	32.10	31.38	
25	12.00	13.06	18.10	17.38		54	26.50	27.56	32.60	31.88	
26	12.50	13.56	18.60	17.88		55	27.00	28.06	33.10	32.38	
27	13.00	14.06	19.10	18.38		56	27.50	28.56	33.60	32.88	
28	13.50	14.56	19.60	18.88		57	28.00	29.06	34.10	33.38	
29	14.00	15.06	20.10	19.38		58	28.50	29.56	34.60	33.88	
30	14.50	15.56	20.60	19.88		59	29.00	30.06	35.10	34.38	
31	15.00	16.06	21.10	20.38		60	29.50	30.56	35.60	34.88	
32	15.50	16.56	21.60	20.88		---	---	---	---	---	5.00

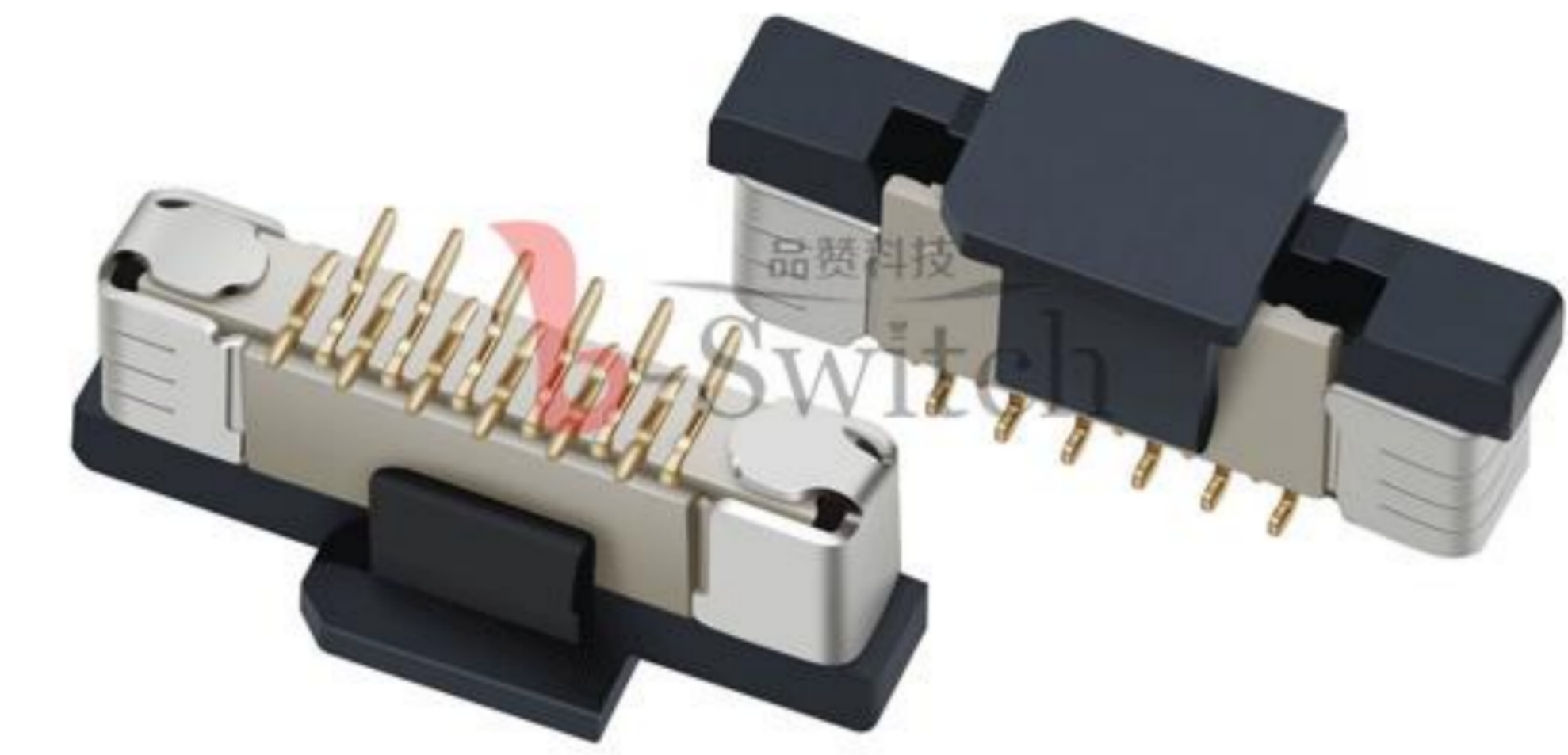

GT-F0504 S V 45 -XX X XX 02

- G-Switch**
- Series No**
- Termipoint**  
S-SMT
- Angle**  
V-180°
- Height**  
45-4.45mm
- Contact**  
01-A Type (Bottom Contacts)  
02-B Type (Top Contacts)
- Terminal Plating**  
11-All G/F  
MT-Matte Tin
- Housing Colour**  
S-Nature
- Pin Q' PY**  
04~60

- G-Switch Specification:**
- 1.Current rated: 0.5A AC/DC
  - 2.Voltage rating: 50V AC/DC
  - 3.Withstanding voltage: 250V AC
  - 4.Contact resistance: 30mΩ max.
  - 5.Insulation resistance: 100MΩ min
  - 6.Durability cycle: 30Cycles
  - 7.Removal force: 0.04kgf/Pin min
  - 8.Operating temperature range: -55°C ~ +85°C

4	SOLDER TABS	BRASS	MATTE Tin
3	CONTACT	PHOSPHOR BRONZE	Gold-Flash On Contact Area
2	COVER	LCP,94V-0	BLACK
1	HOUSING	LCP,94V-0	NATURE
NO.	PART NAME	MATERIAL	REMARK



SCALE: 1:1	UNIT: mm	Title: FPC 0.50mm Pitch 180° SMT Type H4.50mm Connector	
SIZE: A4		Title: FPC 0.50mm Pitch 180° SMT Type H4.50mm Connector	
Unless otherwise General Tolerance:		Title: FPC 0.50mm Pitch 180° SMT Type H4.50mm Connector	
X	±0.40	Title: FPC 0.50mm Pitch 180° SMT Type H4.50mm Connector	
X.x	±0.30	Title: FPC 0.50mm Pitch 180° SMT Type H4.50mm Connector	
X.xx	±0.20	Title: FPC 0.50mm Pitch 180° SMT Type H4.50mm Connector	
X°	±5°	Title: FPC 0.50mm Pitch 180° SMT Type H4.50mm Connector	
X.x°	±3°	Title: FPC 0.50mm Pitch 180° SMT Type H4.50mm Connector	
Title: FPC 0.50mm Pitch 180° SMT Type H4.50mm Connector		MoIde Code: GT-F0504SV45-XXXXX02	
DRAWN	CHECKED	APPROVED	DATE
Jiang	Hu	Chen	2021.06.28

品赞科技

www.dg-switch.com

REV: A0 SHEET: 2/2